



OPTISONIC 6300 Technical Datasheet

Ultrasonic clamp-on flowmeter for liquids

- Robust sensor rail design for accurate and easy installation
- Advanced diagnostics for verified operation
- Factory calibrated sensors for optimal start-up and performance



1	Product features	4
1.1	Introduction	4
1.2	Variants	6
1.3	Features.....	9
1.4	Options	11
1.5	Measuring principle.....	12
2	Technical data	13
2.1	Technical data.....	13
2.2	Dimensions and weight	25
2.2.1	Housing	25
2.2.2	Clamp-on sensor rail.....	26
2.2.3	Mounting plate of field housing	28
2.2.4	Mounting plate of wall-mounted housing	28
3	Installation	29
3.1	Intended use	29
3.2	Pre-installation requirements	29
3.3	General requirements	29
3.4	Installation and safety instructions.....	29
3.5	Installation conditions	31
3.5.1	Inlet, outlet and recommended mounting area	31
3.6	Horizontal (long) pipes	32
3.7	Bends in 2 or 3 dimensions	32
3.8	Bends	33
3.9	T-section	34
3.10	Open feed or discharge	34
3.11	Position of pump	34
3.12	Position of control valve	35
3.13	Pipe diameters and sensor rail(s) construction	35
3.14	Installation instructions for X mode configuration	36
3.15	Installation for energy measurement	37
3.16	Installation of the converter	38
3.16.1	Pipe mounting	38
3.16.2	Wall mounting	39
3.16.3	Turning the display of the field housing version	41

4 Electrical connections	42
4.1 Safety instructions.....	42
4.2 Laying electrical cables correctly	42
4.3 Electrical connections signal converter	43
4.4 Power supply	44
4.4.1 Signal converter power supply connections	45
4.4.2 Signal cable to converter	46
4.4.3 Example of connecting the cable extension (splitter) box	49
4.5 Modular inputs/outputs connections	50
4.5.1 Combinations of the inputs/outputs (I/Os)	51
4.5.2 Description of the CG-number.....	52
4.5.3 Fixed, non-alterable input/output versions.....	53
4.5.4 Alterable input/output versions.....	54
5 Application form	55
6 Notes	57

1.1 Introduction

The **OPTISONIC 6300** is the stationary ultrasonic clamp-on flowmeter for liquid applications. The specific KROHNE design of the sensor rails guarantees the user always simple and quick installation with the highest possible performance.

The system consists of adjustable sensor rail(s) with the most clever designed fixing units for simple installation and maintenance in combination with industrial designed and approved ultrasonic flow converters. Installation can be done on both new or existing pipes for retrofitting, with hardly any limitations on the pipe material, sizes and conditions.

The flowmeter will be delivered factory-calibrated, making start-up immediate and installation simple. This can be done without any process interruption.

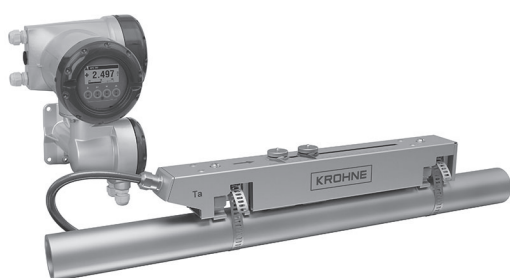

Figure 1-1: OPTISONIC 6000 Small rail with UFC 300 F

Highlights

- Sensor rails in stainless steel with easy installation and alignment
- Robust industrial design to provide maximum reliability
- Factory calibrated sensors for optimal start-up and performance
- Quick and easy access to pipe/transducer contact surfaces
- Sensor rails for temporary or permanent usage underwater
- Standard industrial communications protocols available
- Advanced diagnostics in accordance with NAMUR NE 107 simplifies maintenance
- Dual-path or X mode configuration for maximum performance and reliability
- High temperature and Offshore version available
- Reflect mode setup simplifies and ensures ideal alignment of sensors
- Direct mode available for challenging conditions
- Installation wizard for simple guided commissioning
- Intrinsically safe transducers for safe installation and maintenance

Industries

- Chemicals
- Power plants
- Water
- District heating/cooling
- Oil & Gas
- Semi-conductor
- Food & Beverages
- Pharmaceuticals
- Utilities

Applications

- General process monitoring
- Chemical addition
- Cooling & heating circuits
- Heat consumption/ energy measurement
- Refined hydrocarbons
- Potable water
- De-ionized and demineralized water
- Sanitary flow rate measurements
- Purified water
- HVAC
- Acids, toxins and corrosives

1.2 Variants

The **OPTISONIC 6300** flowmeter consist of a small, medium or large rail(s) containing the ultrasonic transducers in combination with an ultrasonic signal converter:

OPTISONIC 6000 (sensor rail) + UFC 300 (Ultrasonic Flow Converter) = OPTISONIC 6300
Sensor rail material: stainless steel 316L.

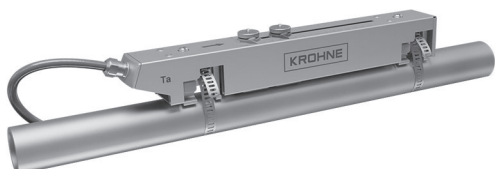

Small sensor version, for small pipe diameters
DN15...100 / ½...4"



Medium sensor version, for medium size pipes
DN50...400 / 2...16"

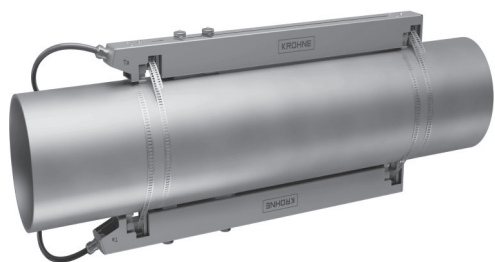

Medium sensor in X mode for pipe sizes
DN50...1250 / 2...50"



Large sensor version in V mode for pipe sizes
DN200...2000 / 8...80"



Large sensor version in Z mode for pipe sizes
DN200...4000 / 8...160"

Single and dual path configuration

The OPTISONIC 6300 flowmeter uses the UFC 300 ultrasonic signal converter which is designed to control one or two measuring paths continuously. The two paths can be used as a dual path measurement on a single pipe for maximum reliability, or as two flowmeters on two separate pipes for maximum flexibility.

Single path variants

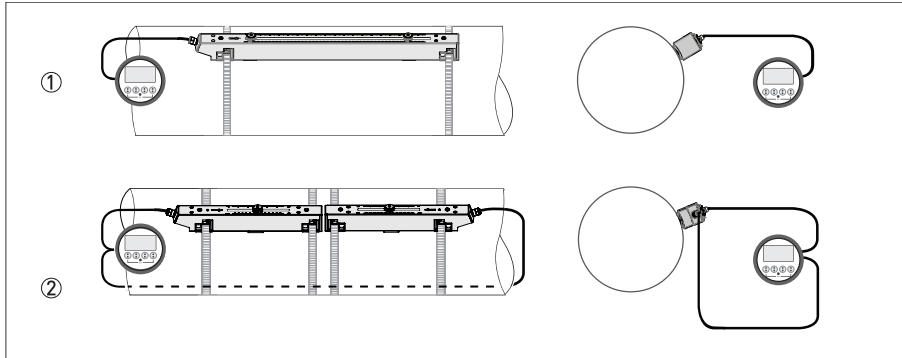

Figure 1-2: Overview of single path variants

- ① 1 path installed on 1 pipe (small or medium sensor rail)
- ② 1 path installed on 1 pipe (2 large sensor rails in V-mode)

Dual-path variants

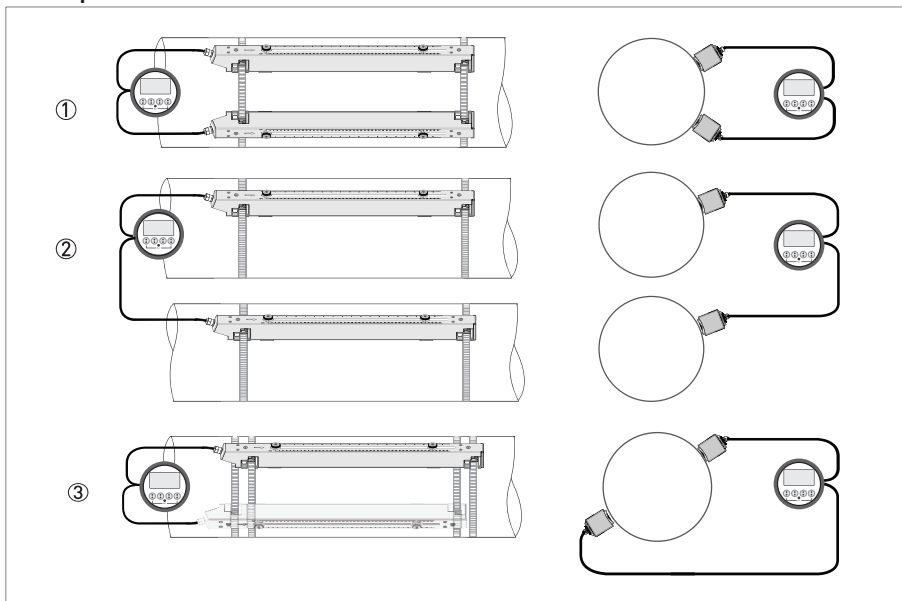

Figure 1-3: Overview of dual-path variants

- ① 2 path installed on 1 pipe (small, medium or large rails)
- ② 2 path installed on 2 pipes (small, medium or large rails)
- ③ 2 path in X mode, installed on 1 pipe (medium rails)

UFC 300 ultrasonic signal converter

**UFC 300 W**

- Wall mounted or on a 2" pipe
- Polyamide-polycarbonate housing
- For non hazardous area (non-Ex)
- IP65/66, NEMA 4/4X

**UFC 300 F**

- Robust industrial field version
- Die-cast epoxy coated aluminum or stainless steel housing
- For hazardous and non hazardous area (Ex and non Ex)
- IP66/67, NEMA 4X/6

1.3 Features

Installation sensor rail

The measurement accuracy is largely determined by the quality of the installation of the clamp-on flow sensor which must be precisely installed and properly aligned.

The OPTISONIC 6300 sensor is always provided with in-rail mounted transducers. A rail allows for accurate fixation of the transducer distance, guaranteeing their proper alignment.



Figure 1-4: Sensor rail with easily adjustable transducers

Reduced maintenance effort

For a continuous accurate and reliable operation the transducers have to be in optimal contact with the pipe surface. Periodic cleaning and/or re-greasing of the transducers is required to ensure a good acoustic connection with the pipe. By being able to unlock and tilt the transducers without changing the transducer position, maintenance is simplified and less time consuming, as the rail is put back exactly in the same position. This eliminates the need for re-adjustments or recommissioning.

To reduce maintenance intervals, standard supplied solid pads can be used (optionally) as acoustic coupling material. In general, grease will have a better acoustic coupling, but the solids pads can be the best solution for a high-temperature application (where the coupling grease may deteriorate more quickly). Also suitable for applications in general where the maintenance interval should be reduced or avoided or in cases where access is difficult.



Figure 1-5: Sensor rail with easy access to the transducers

X mode

For an easy installation, optimal accuracy, maximum reliability and reducing risk: **X-mode**

By positioning two rails opposite each other on the pipe a dual, direct path solution is established. This provides the following advantages:

- A direct path without reflection lowers measurement uncertainty and risk on path loss.
- Dual path provides redundancy. A failing path is automatically compensated by the dynamic path replacement.

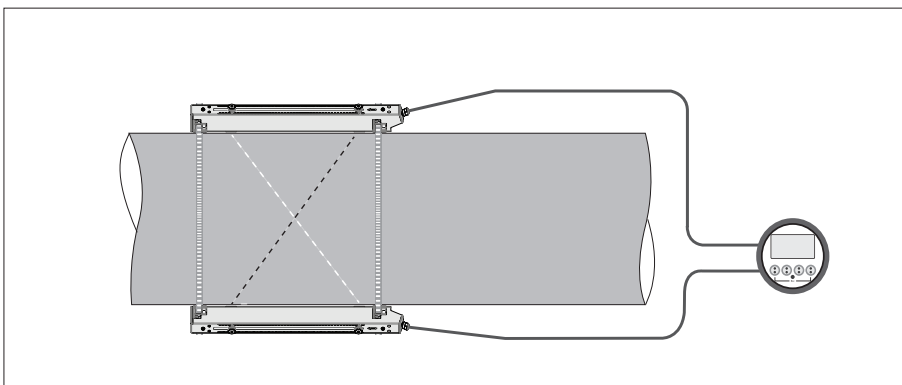





Figure 1-6: X beam configuration of medium version

Diagnostic features

By featuring several diagnostic options the quality of the measurement can be monitored over time. Signal quality parameters like; signal to noise, signal strength and stability are available for monitoring changes in process, fluid properties, product change, empty pipe, cavitation and so on. This allows for condition-based maintenance, keeping the flowmeter in optimal condition and avoiding unplanned downtime. Diagnostics are in full compliance with NAMUR NE 107 available through the communication interfaces or shown in the display.

-  Failure
Output signal invalid
-  Check function
Output signal (temporarily) invalid
-  Out of specification
Unreliability of output signal
-  Maintenance required
Output signal still valid

UFC 300 diagnostic capabilities: NE107

- NE107 icons for status messages and error handling
- visible on UFC 300 display
 - via all communication protocols
 - Status messages are grouped by problem source
 - User can change group or priority

1.4 Options

Energy (heat/cold) measurement

The OPTISONIC 6300 standalone energy measurement feature can be used for cooling and heating applications.

Using one or two temperature sensors connected directly to the signal converter. Thermal power and totalised energy are available on the display and as an output signal.

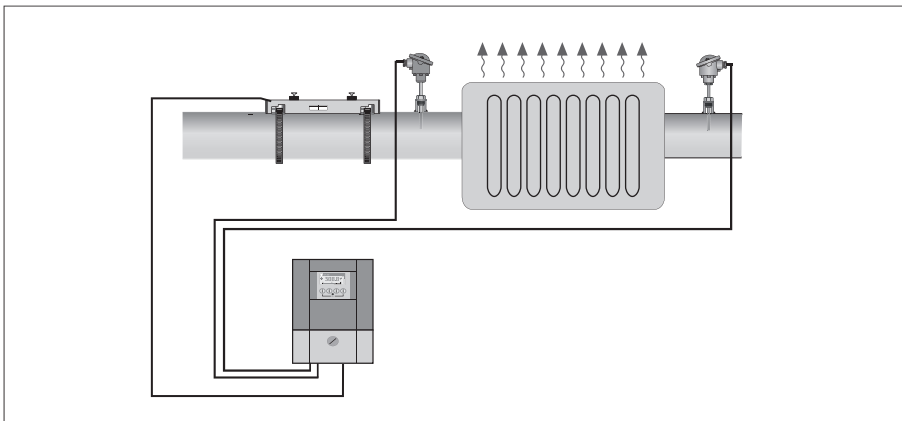

Figure 1-7: Energy system set-up

eXtended-Temperature (XT)

The XT versions are available for all sensor rail(s) sizes to measure liquids up to 200°C/392°F with:

- Stainless steel sensor rails and cable glands
- High temperature transducer versions
- Signal cable with protection sleeve (1 meter)

In addition these version is also available for use in harsh environments like Offshore



eXtended Temperature / Offshore variant

- Refineries
- Chemical plants
- Energy applications
- Offshore oil and gas applications

1.5 Measuring principle

- Like canoes crossing a river, acoustic signals are transmitted and received along a diagonal measuring path.
- A sound wave going downstream with the flow travels faster than a sound wave going upstream against the flow.
- The difference in transit time is directly proportional to the mean flow velocity of the medium.

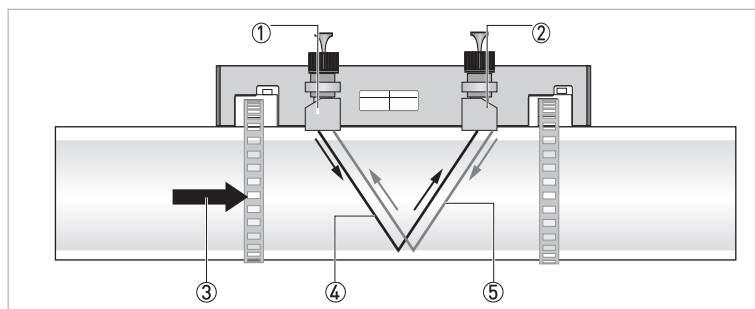

Figure 1-8: Measuring principle (example reflected path set-up)

- ① Transducer A
- ② Transducer B
- ③ Flow velocity
- ④ Transit time from transducer A to B
- ⑤ Transit time from transducer B to A

2.1 Technical data

- *The following data is provided for general applications. If you require data that is more relevant to your specific application, please contact us or your local sales office.*
- *Additional information (certificates, special tools, software,...) and complete product documentation can be downloaded free of charge from the website (Downloadcenter).*

Measuring system

Measuring principle	Ultrasonic transit time
Application range	Flow measurement of liquids
Measured value	
Primary measured value	Transit time
Secondary measured value	Volume flow, mass flow, flow speed, flow direction, speed of sound, gain, signal to noise ratio, diagnosis value, reliability of flow measurement, quality of the acoustic signal. Optional: thermal power, thermal energy, temperature.

Design

The measurement system consists of a measuring sensor rail and a signal converter. It is only available as a separate (remote) version.	
Signal converter	
Wall-mounted housing (W); remote version	UFC 300 W (general purpose)
Field housing (F); remote version	UFC 300 F (option: Ex version)
Sensor rail(s)	
Standard	Small, medium or large stainless steel version
Optional	Medium rail for X mode All sensor rail(s) (small, medium and large) are available in XT version (eXtended Temperature), Offshore version
Diameter ranges	
Small	DN15...100 / ½...4" Outer diameter must be at least 20 mm / 0.79"
Medium	DN50...400 / 2...16"
Medium X - mode	DN200...1250 / 8...50"
Large	DN200...4000 / 8...160" Outer diameter must be smaller than 4300 mm / 169.29"
Signal converter	
Inputs/outputs	Current (incl. HART®), pulse, frequency and/or status output, limit switch and/or control input (depending on the I/O version).
Counters	Two internal counters with a maximum of 8 counter places (e.g. for counting volume and/or mass units).
Verification and self-diagnostics	Integrated verification, diagnostic functions: measuring device, process, measured values, device configuration, empty pipe detection, bar graph etc.
Communication interfaces	HART® 7, Foundation Fieldbus, Profibus, Modbus RS485 (option).

Display and user interface	
Graphic display	LCD; backlit white
	Size: 128 x 64 pixels; corresponds to 59 x 31 mm = 2.32" x 1.22"
	Display turnable in 90° steps
Operator elements	Four optical and mechanical pushbuttons for operator control of the signal converter without opening the housing
	Option: infrared interface (GDC)
Remote control	PACTware® including Device Type Manager (DTM)
	HART® hand-held communicator (Emerson), AMS (Emerson), PDM (Siemens).
	All DTM's and drivers are available at the internet homepage of the manufacturer
Display functions	
Operating menu	Programming of parameters at 2 measured value pages, 1 status page, 1 graphic page (measured values and descriptions adjustable as required).
Language of display texts	English, German, French, Russian.
Measurement functions	Units: Metric, British and US units selectable from a list for volume/mass flow and counting, velocity, temperature.
	Measured values: Volume flow, mass flow, flow speed, velocity of sound, gain, signal to noise ratio, flow direction, diagnostics.
Diagnostic functions	Standards: VDI/NAMUR NE 107
	Status messages: the output of status messages via display, current and/or status output, HART® or via other bus interfaces.
	Sensor diagnostics: per acoustic path velocity of sound, flow speed, gain, signal to noise ratio.
	Process diagnostics: empty pipe, signal integrity, cabling, flow conditions.
	Signal converter diagnostics: data bus monitoring, I/O connections, electronics temperature, parameter and data integrity.

Measuring accuracy

Reference conditions	Medium: water
	Temperature: 20°C / 68°F
	Pressure: 1 bar/14.5 psi
	Straight inlet section: 10 DN
	Straight outlet section: 5 DN
Maximum measuring error	≥ DN50 / 2 inch < ± 1% of the actual measured flow rate; for 0.5...20 m/s / 1.64...65.6 ft/s < ± 5 mm/s / 0.2 inch/s for 0.1...0.5 m/s / 0.33...1.64 ft/s
	< DN50 / 2 inch < ± 3% of the actual measured flow rate; for 0.5...20 m/s / 1.64...65.6 ft/s < ± 15 mm/s / 0.6 inch/s for 0.1...0.5 m/s / 0.33...1.64 ft/s.
Repeatability	± 0.2%

Operating conditions

Temperature	
Process temperature	Standard version: -40...+120°C / -40...+248°F
	XT version: -40...+200°C / -40...+392°F
Ambient temperature	Sensor: -40...+70°C / -40...+158°F
	Standard (die-cast aluminium converter housing): -40...+65°C / -40...+149°F
	Standard (polyamide converter housing): -40...+65°C / -40...+149°F
	Option (die-cast stainless steel converter housing): -40...+60°C / -40...+140°F
	Ambient temperatures below -25°C / -13°F may affect the readability of the display.
Protect the signal converter from external heat sources such as direct sunlight, as higher temperatures reduce the life cycle of all electronic components.	
Storage temperature	-50...+70°C / -58...+158°F
Pipe specifications	
Material	Metal, plastic, ceramic, asbestos cement, internal / external coated pipes (coatings and liners fully bonded to pipe wall).
Pipe wall thickness	< 200 mm / 7.87"
Liner thickness	< 20 mm / 0.79"
Media properties	
Physical condition	Liquid, single phase (well mixed, rather clean).
Viscosity	< 200 cSt (general guideline)
	Maximal measurable viscosity depends on density and pipe diameter
	For higher viscosities please contact your local representative.
Permissible gas content (volume)	≤ 2%
Permissible solid content (volume)	≤ 5%
Flow range	0.1...20 m/s (turn down 200:1)

Installation conditions

Installation	For detailed information refer to <i>Installation and safety instructions</i> on page 29.
Measurement configuration	Single path, single pipe or dual-path/dual-pipe
Inlet run	≥ 10 DN straight length
Outlet run	≥ 5 DN straight length
Dimensions and weights	For detailed information refer to <i>Dimensions and weight</i> on page 25.

Materials

Sensor rail(s)	Standard (small / medium / large version)
	Rail construction: stainless steel 316 – 1.4404
	Transducer: ceramic piezo potted in PSU (Polysulfone)
	Cable connection: NPB
	Option stainless steel eXtended Temperature / Offshore version (small / medium / large version)
	Rail construction: stainless steel 316 – 1.4404
	Transducer XT: ceramic piezo protected with PAI 4203/PA
Connection cable/splitter) box	Cable connection: stainless steel 316 – 1.4404
	Coated aluminium / stainless steel (pending)
Coupling media	Coupling grease: mineral gel (standard); high temperature vacuum gel (XT)
	Coupling pads: FKM
Converter	Standard
	F version: die-cast aluminum; standard coating
	W version: polyamide-polycarbonate
	Option
	F version: stainless steel 316 / 1.4408
Cable	Coating: standard and offshore coating
	Double shielded coax cables
Cable glands	Outer jacket: Polyester elastomer
	Standard: nickel plated brass for cable 8-12 mm For Extended temperature / Offshore: stainless steel 316 L

Electrical connections

Description of used abbreviations; Q = flow rate; I_{max} = maximum current; U_{in} = input voltage; U_{int} = internal voltage; U_{ext} = external voltage; $U_{int, max}$ = maximal internal voltage	
General	Electrical connection is carried out in conformity with the VDE 0100 directive "Regulations for electrical power installations with line voltages up to 1000 V" or equivalent national specifications.
Power supply	Standard: 100...230 VAC (15% / +10%); 50/60 Hz
	Option: 24 VDC (tolerance range: -55% / +30%) 24 VAC/DC (AC: -15% / +10%; 50/60 Hz, DC; -25% / +30%)
Power consumption	AC: 22 VA
	DC: 12 W
Signal cable	Use only the delivered, double shielded coax cables
	Standard length: 6 m / 19 ft or 10 m / 32 ft
	Optional: extension cable with cable (splitter) box: per 5 m / 16 ft up to 30 m / 96 ft
	To connect two sets of large rails a cable (splitter) box with an extension cable is required.
Cable entries	1 or 2 cable entries for signal cables per flow converter
	Standard: M20 x 1.5 (8...12 mm)
	Option: ½" NPT; PF ½

Inputs and outputs

General	All in- and outputs are galvanically isolated from each other and from all other circuits.		
	All operating data and output values can be adjusted.		
Description of used abbreviations	U_{ext} = external voltage; R_L = load + resistance; U_o = terminal voltage; I_{nom} = nominal current. Safety limit values (Ex i): U_i = max. input voltage; I_i = max. input current; P_i = max. input power rating; C_i = max. input capacity; L_i = max. input inductivity.		
Current output			
Output data	Measurement of volume flow, mass flow, flow speed, velocity of sound, gain, SNR, diagnostics (flow speed, VoS, SNR, gain), NAMUR NE 107, HART® communication.		
Temperature coefficient	Typically ± 30 ppm/K		
Settings	Without HART®		
	Q = 0%: 0...20 mA; Q = 100%: 10...20 mA		
	Error identification: 0...22 mA		
	With HART®		
	Q = 0%: 4...20 mA; Q = 100%: 10...20 mA		
	Error identification: 3.5...22 mA		
Operating data	Basic I/Os	Modular I/Os	Ex-i
Active	$U_{int,nom} = 24$ VDC $I \leq 22$ mA $R_L \leq 1$ k Ω		$U_{int,nom} = 20$ VDC $I \leq 22$ mA $R_L \leq 450$ Ω
			$U_o = 21$ V $I_o = 90$ mA $P_o = 0.5$ W $C_o = 90$ nF / $L_o = 2$ mH $C_o = 110$ nF / $L_o = 0.5$ mH
Passive	$U_{ext} \leq 32$ VDC $I \leq 22$ mA $U_o \geq 1.8$ V $R_L \leq (U_{ext} - U_o) / I_{max}$		$U_{ext} \leq 32$ VDC $I \leq 22$ mA $U_o \geq 4$ V $R_L \leq (U_{ext} - U_o) / I_{max}$
			$U_i = 30$ V $I_i = 100$ mA $P_i = 1$ W $C_i = 10$ nF $L_i \sim 0$ mH
HART®			
Description	HART® protocol via active and passive current output		
	HART® version: V7		
	Universal HART® parameter: completely integrated		
Load	≥ 230 Ω at HART® test point: please observe maximum value for current output!		
Multidrop	Yes, current output = 10% e.g. 4 mA		
	Multidrop addresses adjustable in operation menu 0...63		
Device drivers	DD for FC 375/475, AMS, PDM, DTM for FDT.		

Pulse or frequency output			
Output data	Volume flow, mass flow.		
Function	Adjustable as pulse or frequency output		
Pulse rate/frequency	0.01...10000 pulses/s or Hz		
Settings	For Q = 100%: 0.01...10000 pulses per second or pulses per unit volume		
	Pulse width: setting automatic, symmetric or fixed (0.05...2000 ms).		
Operating data	Basic I/Os	Modular I/Os	Ex-i
Active	-	$U_{nom} = 24 \text{ VDC}$ $f_{max} \leq 100 \text{ Hz}$: $I \leq 20 \text{ mA}$ $R_{L, max} = 47 \text{ k}\Omega$ open: $I \leq 0.05 \text{ mA}$ closed: $U_{0, nom} = 24 \text{ V}$ at $I = 20 \text{ mA}$	-
		f_{max} in operating menu set to: $100 \text{ Hz} < f_{max} \leq 10 \text{ kHz}$: $I \leq 20 \text{ mA}$ $R_L \leq 10 \text{ k}\Omega$ for $f \leq 1 \text{ kHz}$ $R_L \leq 1 \text{ k}\Omega$ for $f \leq 10 \text{ kHz}$ open: $I \leq 0.05 \text{ mA}$ closed: $U_{0, nom} = 22.5 \text{ V}$ at $I = 1 \text{ mA}$ $U_{0, nom} = 21.5 \text{ V}$ at $I = 10 \text{ mA}$ $U_{0, nom} = 19 \text{ V}$ at $I = 20 \text{ mA}$	
Passive	$U_{ext} \leq 32 \text{ VDC}$	f_{max} in operating menu set to: $f_{max} \leq 100 \text{ Hz}$: $I \leq 100 \text{ mA}$ $R_{L, max} = 47 \text{ k}\Omega$ $R_{L, min} = (U_{ext} - U_0) / I_{max}$ open: $I \leq 0.05 \text{ mA}$ at $U_{ext} = 32 \text{ VDC}$ closed: $U_{0, max} = 0.2 \text{ V}$ at $I \leq 10 \text{ mA}$ $U_{0, max} = 2 \text{ V}$ at $I \leq 100 \text{ mA}$	-
		f_{max} in operating menu set to: $100 \text{ Hz} < f_{max} \leq 10 \text{ kHz}$: $I \leq 20 \text{ mA}$ $R_L \leq 10 \text{ k}\Omega$ for $f \leq 1 \text{ kHz}$ $R_L \leq 1 \text{ k}\Omega$ for $f \leq 10 \text{ kHz}$ $R_{L, min} = (U_{ext} - U_0) / I_{max}$ open: $I \leq 0.05 \text{ mA}$ at $U_{ext} = 32 \text{ VDC}$ closed: $U_{0, max} = 1.5 \text{ V}$ at $I \leq 1 \text{ mA}$ $U_{0, max} = 2.5 \text{ V}$ at $I \leq 10 \text{ mA}$ $U_{0, max} = 5.0 \text{ V}$ at $I \leq 20 \text{ mA}$	
NAMUR	-	Passive to EN 60947-5-6 open: $I_{nom} = 0.6 \text{ mA}$ closed: $I_{nom} = 3.8 \text{ mA}$	Passive to EN 60947-5-6 open: $I_{nom} = 0.43 \text{ mA}$ closed: $I_{nom} = 4.5 \text{ mA}$
			$U_I = 30 \text{ V}$ $I_I = 100 \text{ mA}$ $P_I = 1 \text{ W}$ $C_I = 10 \text{ nF}$ $L_I \sim 0 \text{ mH}$

Status output / limit switch			
Function and settings	Adjustable as automatic measuring range conversion, display of flow direction, overflow, error, switching point or empty pipe detection.		
	Valve control with activated dosing function		
	Status and/or control: ON or OFF		
Operating data	Basic I/Os	Modular I/Os	Ex-i
Active	-	$U_{int} = 24 \text{ VDC}$ $I \leq 20 \text{ mA}$ $R_{L, max} = 47 \text{ k}\Omega$ open: $I \leq 0.05 \text{ mA}$ closed: $U_{0, nom} = 24 \text{ V}$ at $I = 20 \text{ mA}$	-
Passive	$U_{ext} \leq 32 \text{ VDC}$ $I \leq 100 \text{ mA}$ $R_{L, max} = 47 \text{ k}\Omega$ $R_{L, min} = (U_{ext} - U_0) / I_{max}$ open: $I \leq 0.05 \text{ mA}$ at $U_{ext} = 32 \text{ VDC}$ closed: $U_{0, max} = 0.2 \text{ V}$ at $I \leq 10 \text{ mA}$ $U_{0, max} = 2 \text{ V}$ at $I \leq 100 \text{ mA}$	$U_{ext} = 32 \text{ VDC}$ $I \leq 100 \text{ mA}$ $R_{L, max} = 47 \text{ k}\Omega$ $R_{L, min} = (U_{ext} - U_0) / I_{max}$ open: $I \leq 0.05 \text{ mA}$ at $U_{ext} = 32 \text{ VDC}$ closed: $U_{0, max} = 0.2 \text{ V}$ at $I \leq 10 \text{ mA}$ $U_{0, max} = 2 \text{ V}$ at $I \leq 100 \text{ mA}$	-
NAMUR	-	Passive to EN 60947-5-6 open: $I_{nom} = 0.6 \text{ mA}$ closed: $I_{nom} = 3.8 \text{ mA}$	Passive to EN 60947-5-6 open: $I_{nom} = 0.43 \text{ mA}$ closed: $I_{nom} = 4.5 \text{ mA}$ <hr/> $U_I = 30 \text{ V}$ $I_I = 100 \text{ mA}$ $P_I = 1 \text{ W}$ $C_I = 10 \text{ nF}$ $L_I = 0 \text{ mH}$

Control input			
Function	Hold value of the outputs (e.g. for cleaning work), set value of the outputs to "zero", counter and error reset, stop counter, range conversion, zero calibration.		
	Start of dosing when dosing function is activated		
Operating data	Basic I/Os	Modular I/Os	Ex-i
Active	-	$U_{int} = 24 \text{ VDC}$ Terminals open: $U_{0, nom} = 22 \text{ V}$ Terminals bridged: $I_{nom} = 4 \text{ mA}$ On: $U_0 \geq 12 \text{ V}$ with $I_{nom} = 1.9 \text{ mA}$ Off: $U_0 \leq 10 \text{ V}$ with $I_{nom} = 1.9 \text{ mA}$	-
Passive	$8 \text{ V} \leq U_{ext} \leq 32 \text{ VDC}$ $I_{max} = 6.5 \text{ mA}$ at $U_{ext} \leq 24 \text{ VDC}$ $I_{max} = 8.2 \text{ mA}$ at $U_{ext} \leq 32 \text{ VDC}$ Contact closed (On): $U_0 \geq 8 \text{ V}$ with $I_{nom} = 2.8 \text{ mA}$ Contact open (Off): $U_0 \leq 2.5 \text{ V}$ with $I_{nom} = 0.4 \text{ mA}$	$3 \text{ V} \leq U_{ext} \leq 32 \text{ VDC}$ $I_{max} = 9.5 \text{ mA}$ at $U_{ext} \leq 24 \text{ V}$ $I_{max} = 9.5 \text{ mA}$ at $U_{ext} \leq 32 \text{ V}$ Contact closed (On): $U_0 \geq 3 \text{ V}$ with $I_{nom} = 1.9 \text{ mA}$ Contact open (Off): $U_0 \leq 2.5 \text{ V}$ with $I_{nom} = 1.9 \text{ mA}$	$5.5 \text{ V} \leq U_{ext} \leq 32 \text{ VDC}$ $I_{max} = 6 \text{ mA}$ at $U_{ext} \leq 24 \text{ V}$ $I_{max} = 6.5 \text{ mA}$ at $U_{ext} \leq 32 \text{ V}$ Contact closed (On): $U_0 \geq 5.5 \text{ V}$ or $I \geq 4 \text{ mA}$ Contact open (Off): $U_0 \leq 3.5 \text{ V}$ or $I \leq 0.5 \text{ mA}$
			$U_1 = 30 \text{ V}$ $I_1 = 100 \text{ mA}$ $P_1 = 1 \text{ W}$ $C_1 = 10 \text{ nF}$ $L_1 = 0 \text{ mH}$
NAMUR	-	Active to EN 60947-5-6 Contact open: $U_{0, nom} = 8.7 \text{ V}$ Contact closed (On): $I_{nom} = 7.8 \text{ mA}$ Contact open (off): $U_{0, nom} = 6.3 \text{ V}$ with $I_{nom} = 1.9 \text{ mA}$ Identification for open terminals: $U_0 \geq 8.1 \text{ V}$ with $I \leq 0.1 \text{ mA}$ Identification for short circuited terminals: $U_0 \leq 1.2 \text{ V}$ with $I \geq 6.7 \text{ mA}$	-

PROFIBUS DP	
Description	Galvanically isolated acc. to IEC 61158
Profile version: 3.02	
Automatic data transmission rate recognition (max. 12 MBaud)	
Bus address adjustable via local display at the measuring device	
Function blocks	6 x analogue input block, 3 x totaliser function block, 1 x transducer block, 1 x physical block
Output data	Volume flow, mass flow, velocity of sound, flow speed, gain, SNR, electronic temperature, power supply Diagnostic data (Further meas. values and diagnostic data is available via acyclic access)
PROFIBUS PA	
Description	Galvanically isolated acc. to IEC 61158
	Profile version: 3.02
	Current consumption: 10.5 mA
	Permissible bus voltage: 9...32 V; in Ex application 9...24 V
	Bus interface with integrated reverse polarity protection
	Typical error current FDE (Fault Disconnection Electronic): 4.3 mA
	Bus address adjustable via local display on the measuring device
Function blocks	6 x analogue input block, 3 x totaliser function block, 1 x transducer block, 1 x physical block
Output data	Volume flow, mass flow, velocity of sound, flow speed, gain, SNR, electronic temperature, power supply Diagnostic data (Further meas. values and diagnostic data is available via acyclic access)
FOUNDATION Fieldbus	
Description	Galvanically isolated acc. to IEC 61158
	Current consumption: 10.5 mA
	Permissible bus voltage: 9...32 V; in Ex application 9...24 V
	Bus interface with integrated reverse polarity protection
	Link Master function (LM) supported
	Tested with Interoperable Test Kit (ITK) version 6.0
Function blocks	4 x analogue input, 2 x integrator, 1 x PID
Output data	Volume flow, mass flow, flow speed, electronic temperature, velocity of sound, gain, SNR Diagnostic data

MODBUS			
Description	Modbus RTU; Master/Slave; RS485		
Address range	1...247		
Supported function codes	01, 02, 03, 04, 05, 08, 16, 43.		
Supported Baud rate	1200, 2400, 4800, 9600, 19200, 38400, 57600, 115200 Baud.		
Low-flow cutoff			
On	0...±9.999 m/s; 0...20.0%, settable in 0.1% steps, separately for each current and pulse output.		
Off	0...±9.999 m/s; 0...19.0%, settable in 0.1% steps, separately for each current and pulse output.		
Time constant			
Function	Can be set together for all flow indicators and outputs, or separately for: current, pulse and frequency output, and for limit switches and the 3 internal counters.		
Time setting	0...100 seconds; settable in 0.1 second steps		
Current input			
Function	For connection of temperature sensors 0(4)...20 mA for heat/cold measurement		
Operating data	Basic I/Os	Modular I/Os	Ex i
Active	-	$U_{int} = 24 \text{ VDC}$	$U_{int} = 20 \text{ VDC}$
		$I \leq 22 \text{ mA}$	$I \leq 22 \text{ mA}$
		$I_{max} \leq 26 \text{ mA}$ (electronically limited)	$U_{0, min} = 14 \text{ V}$ at $I \leq 22 \text{ mA}$
		$U_{0, min} = 19 \text{ V}$ at $I \leq 22 \text{ mA}$	No HART®
Passive	-	No HART®	$U_0 = 24.1 \text{ V}$ $I_0 = 99 \text{ mA}$ $P_0 = 0.6 \text{ W}$ $C_0 = 75 \text{ nF} / L_0 = 0.5 \text{ mH}$
		No HART®	No HART®
		$U_{ext} \leq 32 \text{ VDC}$	$U_{ext} \leq 32 \text{ VDC}$
		$I \leq 22 \text{ mA}$	$I \leq 22 \text{ mA}$
Passive	-	$I_{max} \leq 26 \text{ mA}$ (electronically limited)	$U_{0, min} = 4 \text{ V}$ at $I \leq 22 \text{ mA}$
		$U_{0, min} = 5 \text{ V}$ at $I \leq 22 \text{ mA}$	No HART®
		No HART®	$U_I = 30 \text{ V}$ $I_I = 100 \text{ mA}$ $P_I = 1 \text{ W}$ $C_I = 10 \text{ nF}$ $L_I = 0 \text{ mH}$
		No HART®	No HART®

Approvals and certificates

CE	
This device fulfils the statutory requirements of the EU directives. The manufacturer certifies successful testing of the product by applying the CE mark.	
	For full information of the EU directives and standards and the approved certifications, please refer to the EU Declaration of Conformity or the website of the manufacturer.
NAMUR	NE 04, 21, 43, 53, 80, 107
Other approvals and standards	
Non-Ex	Standard
Hazardous areas	
Ex zone 1 - 2	For detailed information, please refer to the relevant Ex documentation. According to European directive 2014/34/EU (ATEX 100a)
IECEX	Sensor:
	Approval number sensor: IECEX KIWA 17.0017X
	Converter (F version only):
	Approval number converter: IECEX KIWA 18.0003X
ATEX	Sensor:
	Approval number: KIWA 17ATEX0034 X
	Converter (F version only):
	Approval number: KIWA 18ATEX0007 X
NEPSI	Approval number: GYJ20.1510X / GYJ20.1511X
Class I, DIV 1 or 2	Option (F version): Approval number; cQPSus LR1338-9
Protection category according to IEC 60529	Signal converter
	W (wall version) IP65/66, NEMA 4/4X
	F (field version) IP66/67, NEMA 4X/6
	Flow sensors
	Stainless steel version: IP66/67 or IP68
Shock resistance	IEC 60068-2-27
	30 g for 18 ms
Vibration resistance	IEC 60068-2-6
	1 g up to 2000 Hz

2.2 Dimensions and weight

2.2.1 Housing

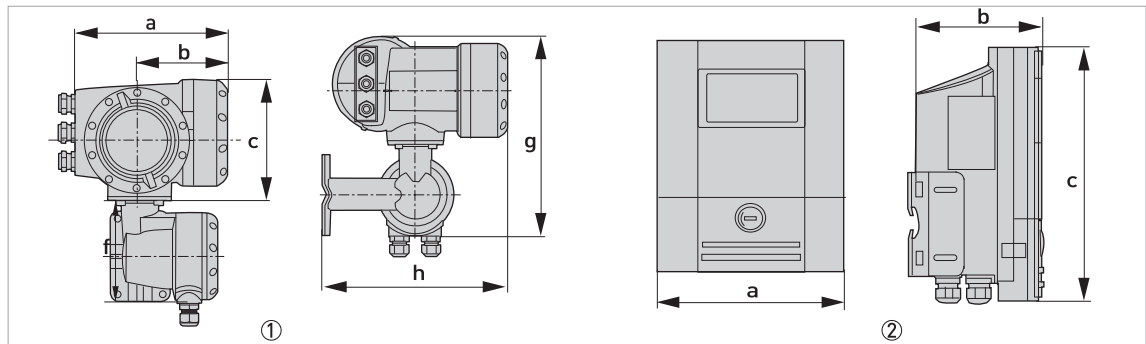

Figure 2-1: Dimensions of housing

- ① Field housing (F) - remote version
- ② Wall-mounted housing (W) - remote version

Version	Dimensions [mm]					Weight [kg]
	a	b	c	g	h	
F	202	120	155	296	277	6.0
W	198	138	299	-	-	2.4

Table 2-1: Dimensions and weight in mm and kg

Version	Dimensions [inch]					Weight [lb]
	a	b	c	g	h	
F	7.75	4.75	6.10	11.60	10.90	13.2
W	7.80	5.40	11.80	-	-	5.3

Table 2-2: Dimensions and weight in inch and lb

The weight of the F version in stainless steel is 13.5 kg / 29.8 lb.

2.2.2 Clamp-on sensor rail

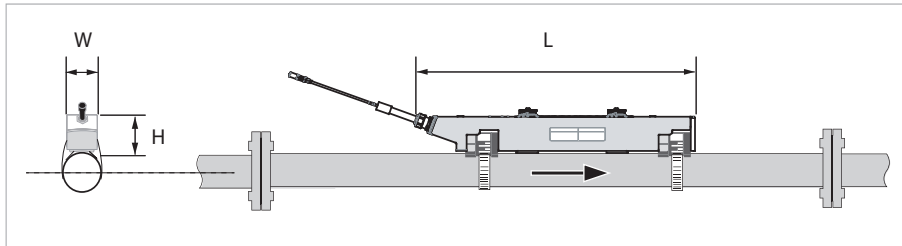

Figure 2-2: Dimensions clamp-on sensor rail(s)

Sensor rail(s)	Dimensions [mm]			Approx. weight (without cable/strip) [kg]
	L	H	W	
Small	412	69	50	1.9
Medium	741	69	50	2.6
Large	412 ①	69 ①	50 ①	3.6

Table 2-3: Dimensions and weight clamp-on sensor rail(s) [mm - kg]

① value for one of the 2 delivered rails

Sensor rail(s)	Dimensions [inches]			Approx. weight (without cable/strip) [lbs]
	L	H	W	
Small	16.2	2.7	2.0	4.2
Medium	29.2	2.7	2.0	5.7
Large	16.2 ①	2.7 ①	2.0 ①	7.9

Table 2-4: Dimensions and weight clamp-on sensor rail(s) [inch - lb]

① value for one of the 2 delivered rails

Cable (splitter) box

Dimension of the aluminium cable (splitter) box for extended connection cable lengths

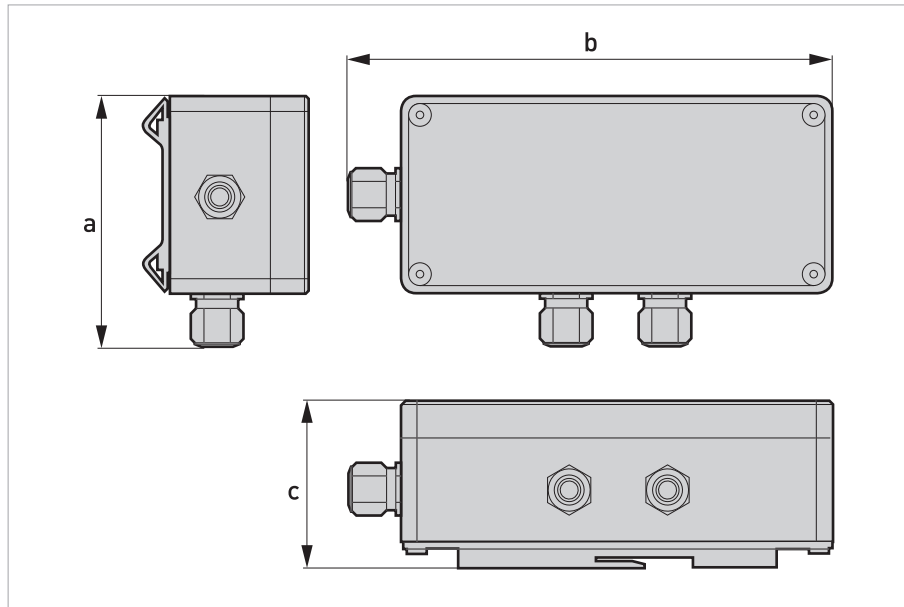

Figure 2-3: Dimensions

	Dimensions [mm]			Approximately weight without cable [kg]
	a	b	c	
Cable box	115	210	67	0.9

Table 2-5: Dimensions and weight cable box [mm - kg]

	Dimensions [inches]			Approximately weight without cable [lbs]
	a	b	c	
Cable box	4.53	8.27	2.64	2.0

Table 2-6: Dimensions and weight cable box [inch - lb]

2.2.3 Mounting plate of field housing

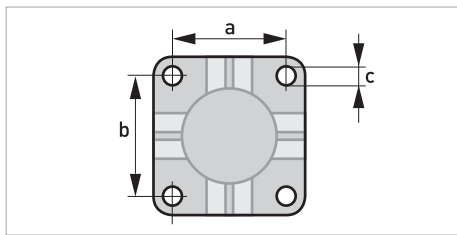

Figure 2-4: Dimensions for mounting plate of field housing

	[mm]	[inch]
a	72	2.8
b	72	2.8
c	Ø9	Ø0.4

Table 2-7: Dimensions in mm and inch

2.2.4 Mounting plate of wall-mounted housing

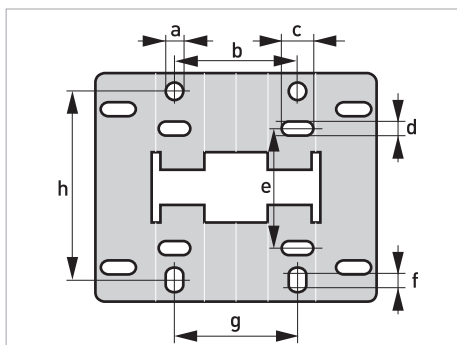

Figure 2-5: Dimensions of mounting plate of wall-mounted housing

	[mm]	[inch]
a	Ø9	Ø0.4
b	64	2.5
c	16	0.6
d	6	0.2
e	63	2.5
f	13	0.5
g	64	2.5
h	98	3.85

Table 2-8: Dimensions in mm and inch

3.1 Intended use

Responsibility for the use of the measuring devices with regard to suitability, intended use and corrosion resistance of the used materials against the measured fluid lies solely with the operator.

The manufacturer is not liable for any damage resulting from improper use or use for other than the intended purpose.

The OPTISONIC 6300 is an ultrasonic clamp-on flowmeter that can be fitted on the outside of the pipeline to measure the flow rate of liquids.

The clamp-on flowmeter is a combination of one or two OPTISONIC 6000 clamp-on sensor(s) and one UFC 300 ultrasonic flow converter.

The overall functionality of the clamp-on flowmeter is the continuous measurement of actual volume flow, mass flow, flow speed, velocity of sound, gain, SNR and diagnosis value.

3.2 Pre-installation requirements

To assure a quick, safe and uncomplicated installation, we kindly request you to make provisions as stated below.

Make sure that you have all necessary tools available:

- Allen key (4 and 5 mm)
- Set of screwdrivers
- Wrench for cable glands and for pipe mounting bracket (remote version only); refer to *Pipe mounting* on page 38

3.3 General requirements

The following precautions must be taken to ensure a reliable installation.

- *Make sure that there is adequate space on the sides.*
- *Protect the signal converter from direct sunlight and install a sunshade if necessary.*
- *Signal converters installed in control cabinets require adequate cooling, e.g. by fan or heat exchanger.*
- *Do not expose the signal converter to intense vibrations and mechanical shocks.*

3.4 Installation and safety instructions

To avoid measuring errors and malfunctioning of the flowmeter due to gas or air inclusions or an empty pipe, please observe the following precautions.

Since gas will collect at the highest point of a pipe, installation of the flowmeter at that location should be avoided at all times. Also, installation in a down going pipe should be avoided since a completely filled pipe may not be guaranteed due to cascading effects. Additionally, flow profile distortion is possible.

If you program the diameter, please note that you use the outer diameter of the pipe.

Specific for sensors rail(s)

- *Be careful when locking the rail back onto the mounting units as your fingers may get stuck between rail and pipe it is mounted on. This may cause injury.*
- *Be careful when mounting the fixation units using the metal strap. The edge of the strap may cause injury.*
- *Do not bend the metal mounting strap. This may cause improper mounting of the fixation units of the sensor rails.*
- *Protect the pipe contact side of the transducer. Scratches or other damages may have a negative impact on its proper functioning.*
- *Before fitting the transducer to the transducer knob in the sensor rail, check the connection groove of the transducer cover for damages or dirt. Clean or replace when dirty or damaged.*
- *Check sensor cabling at regular intervals for damages and wear, as this may cause improper functioning. Replace when necessary.*
- *Check the sensor rail sliding area regularly for dirt or other pollution or excess coupling grease, that may cause improper functioning.*
- *Check the presence of sufficient grease on the transducer pipe contact side in case of acoustic signal failure.*
- *Excess of coupling grease may be removed from the sensor rails and transducers with a dry piece of cloth. Coupling grease on the converter housing may be removed using soapy water.*

The device should be protected from corrosive chemicals or gases and dust/particles accumulation.

3.5 Installation conditions

3.5.1 Inlet, outlet and recommended mounting area

To perform an accurate flow measurement install the sensor rail(s) more than 10 DN of any possible downstream flow disturbance (e.g. elbow, valve, header, pump). Please follow the installation recommendations in the next installation position examples.

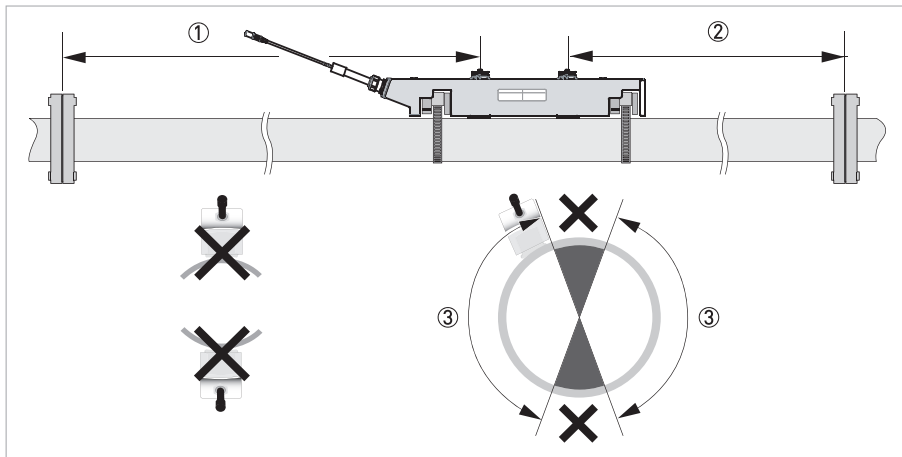

Figure 3-1: Inlet, outlet and recommended mounting area

- ① ≥ 10 DN
- ② ≥ 5 DN
- ③ OK, 120°

Note: especially for XT (eXtended Temperature) versions:

- *The sensor rail(s) must be installed directly on a clean pipe surface (remove any insulation if necessary).*
- *After installation, the sensor can be completely insulated. The signal cable must be protected correctly and kept away from the hot pipe surface.*
- *Always use the correct Personal Protective Equipment (heat-protection, gloves).*

3.6 Horizontal (long) pipes

Horizontal pipes are ideal to install a clamp-on, recommended orientation 45-90 degrees refer to *Inlet, outlet and recommended mounting area* on page 31.

In cases that a full pipe condition is not guaranteed (or not possible):

- Install on a slightly ascending pipe section or at the lowest point of the pipe system.
- Install air/gas release devices (air vent).
- If not possible, control the flow velocity to prevent gasses (air, gas or vapour) from collecting in the upper part, so these will continuously be taken with the flow.
- In partially filled pipes, the clamp-on flowmeter will report incorrect or no flow rates.

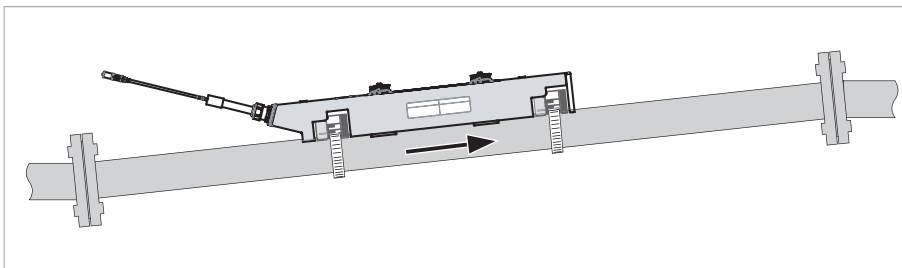

Figure 3-2: Install on a slightly ascending pipe section

3.7 Bends in 2 or 3 dimensions

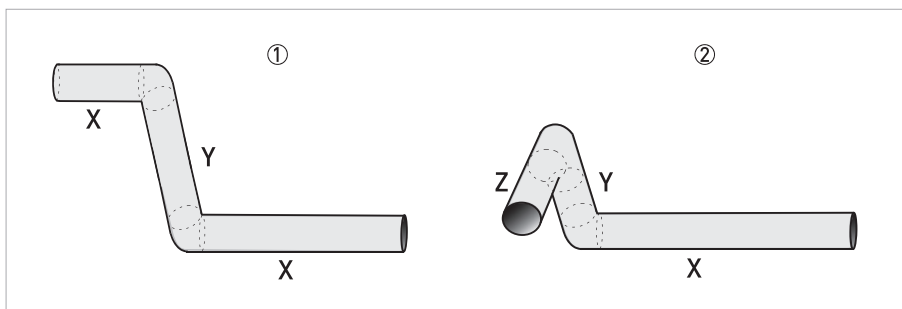

Figure 3-3: 2 and/or 3 dimensional bends upstream of the flowmeter

① 2 dimensions = X/Y

② 3 dimensions = X/Y/Z

Inlet length:

for 2 path using bends in 2 dimensions: ≥ 10 DN; when having bends in 3 dimensions: ≥ 15 DN

for 1 path using bends in 2 dimensions: ≥ 20 DN; when having bends in 3 dimensions: ≥ 25 DN

*2 dimensional bends occur in a vertical **or** horizontal plane (X/Y) only, while 3 dimensional bends occur in both vertical **and** horizontal plane (X/Y/Z).*

3.8 Bends

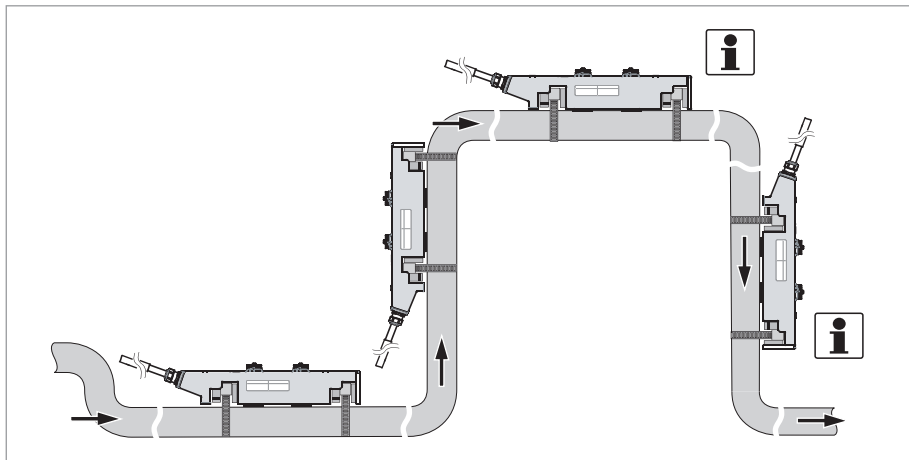

Figure 3-4: Installation in bending pipes (90°)

NOTE!

Recommended installation positions are at a lowered or ascending section of the pipeline installation. Installation at the highest point will enlarge the risk of flowmeter malfunction, because of air/gas bubbles.

Vertical installation in combination with an open surcharge has to be avoided. Vertical installation with a controlled back-pressure is possible.

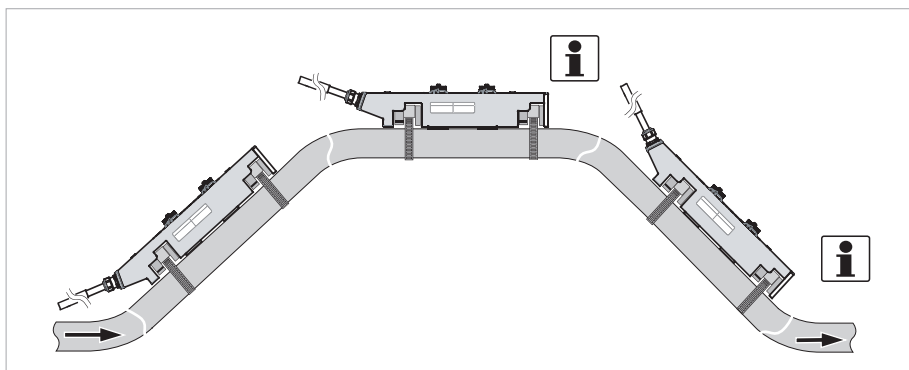

Figure 3-5: Installation in bending pipes (45°)

NOTE!

Vertical installation on a descending slope in the pipeline is only recommended when the back-pressure is controlled.

3.9 T-section

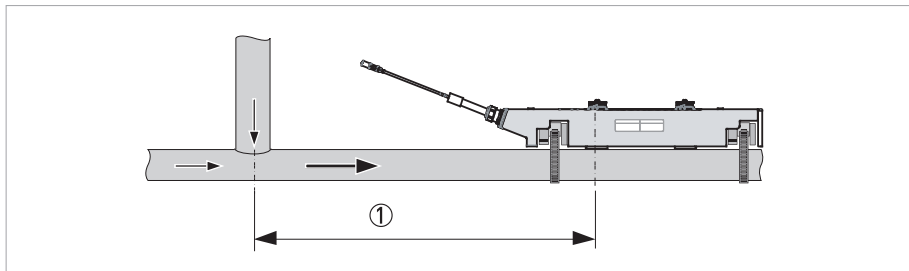

Figure 3-6: Distance behind a T-section

① ≥ 20 DN

3.10 Open feed or discharge

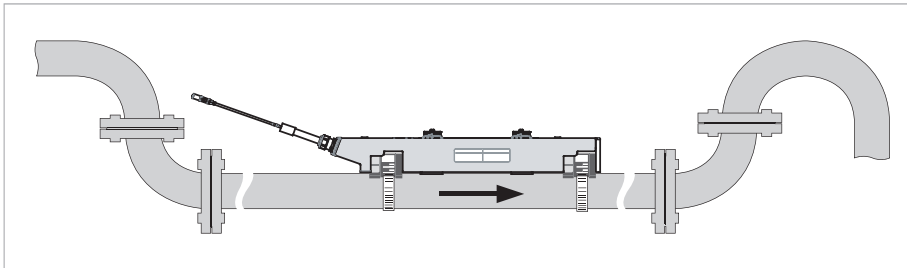

Figure 3-7: Open feed or discharge

Install the flowmeter on a lowered section of the pipeline to ensure a full pipe condition through the meter.

3.11 Position of pump

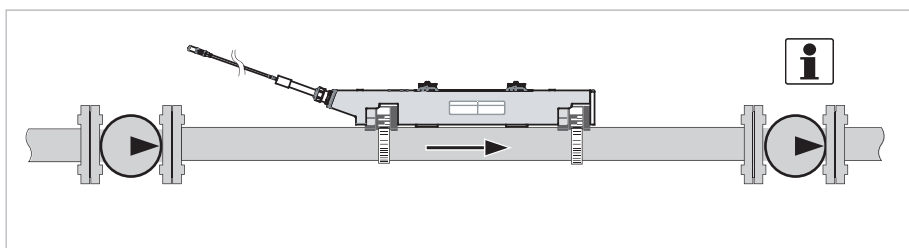

Figure 3-8: Position of pump

NOTE!

Recommended position to install a flowmeter is downstream a pump (on a position where the flow disturbances of the pump are resolved)

A clamp-on flowmeter can be installed in the suction line of a pump if there is no cavitation in the pipeline system.

3.12 Position of control valve

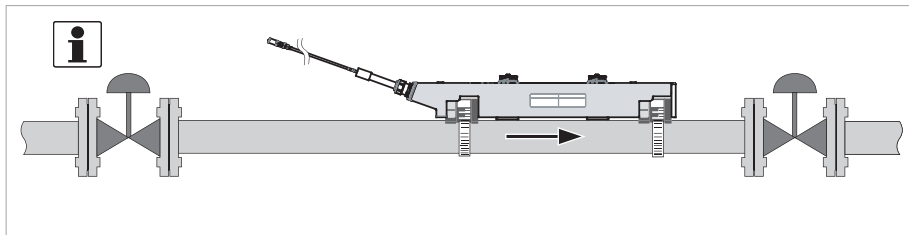

Figure 3-9: Position of control valve

NOTE!

Recommended position to install a flowmeter is upstream a control valve.
 A clamp-on flowmeter can be installed downstream of the control valve if there is no cavitation in the pipeline system (e.g. flow profile disturbances are resolved).

3.13 Pipe diameters and sensor rail(s) construction

NOTE!

Check the ordered rail(s) with the preferred measuring mode

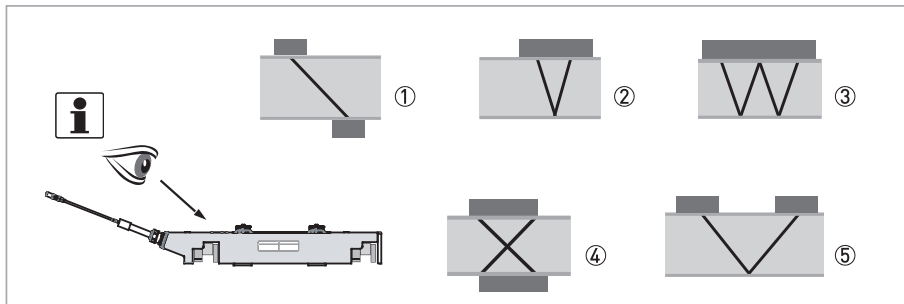

Figure 3-10: Measuring modes

- ① Z-mode
- ② V-mode
- ③ W-mode
- ④ X-mode
- ⑤ V-mode; large set rails

Overview version and measuring modes

Rail version	Diameter range	Preferred measuring modes	Possible measuring modes
Small	DN15...100 / 0.5...4"	< DN25: W-mode (4 traverses)	Small: V mode
		≥ DN25: V-mode (2 traverses)	
Medium	DN50...400 / 2...16"	V-mode (2 traverses)	
	DN50...1250 / 2...50"	X-mode (2 x 1 traverses)	
Large	DN200...2000 / 8...80"	Large: V mode (2 traverses)	
	DN200...4000 / 8...160"	Z-mode (1 traverse)	

Table 3-1: Version and preferred measuring mode

3.14 Installation instructions for X mode configuration

The X mode measurement version of the unit is setup in a 2 path configuration, with a crossed wire connection of 2 medium sensor rails.

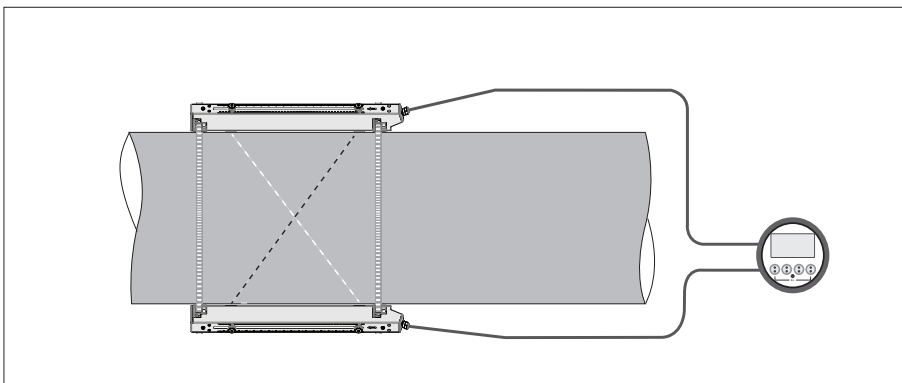

Figure 3-11: X beam configuration of medium version

Install the sensor rails according to the above image. Make sure that the two rails are installed exactly on opposite sides of the pipe.

Check the OPTISONIC 6300 manual for detailed information.

Connect the sensors according to the following instruction:

Sensor Ta

- Blue cable: U1
- Green cable: D2

Sensor Tb

- Blue cable: U2
- Green cable: D1

Set up

Programming of the sensor setup (transducer 1 settings) in the installation menu X :

- Set menu item X4.2 = number of paths → 2
- Set menu item X7.3 = number of traverses → change to 1 traverse
- Set menu item X7.4 = transducer distance →
the exact distance between up transducer of Ta to the down transducer of Tb
- Repeat the process for transducer 2

3.15 Installation for energy measurement

The combination of the measured flow rate and a temperature difference over a heat/cold producer/consumer can be used to determine the amount of energy used by that device. The temperature difference can be measured with temperature transmitters, connected to the signal converter. In this case, the temperature difference is determined by measuring the temperature before and after the heat/cold producer/consumer.

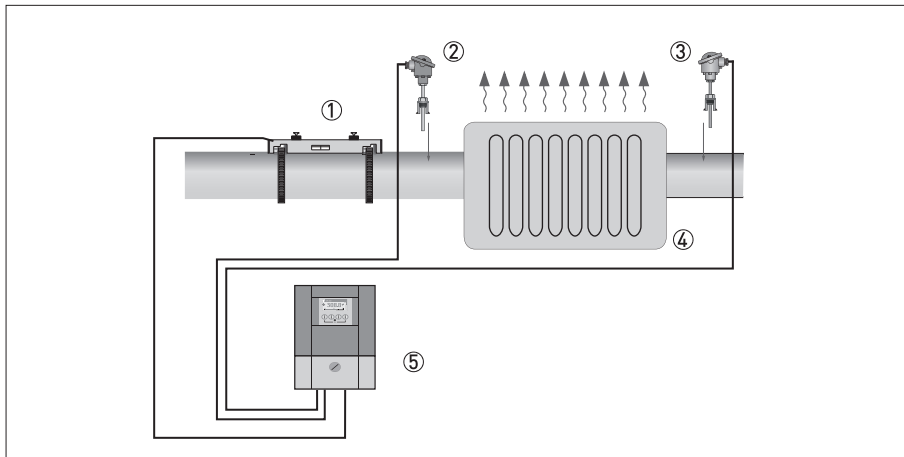

Figure 3-12: Energy measurement of heat/cold producer/consumer

- ① Installed small, medium or large sensor rail(s)
- ② PT 100 temperature sensor with 4-20 mA transmitter, upstream of the heat/cold producer/consumer
- ③ PT 100 temperature sensor with 4-20 mA transmitter, downstream of the heat/cold producer/consumer
- ④ Observed heating or cooling object
- ⑤ UFC 300 signal converter

Please find more detailed information in the OPTISONIC 6300 manual.

3.16 Installation of the converter

Assembly materials and tools are not part of the delivery. Use the assembly materials and tools in compliance with the applicable occupational health and safety directives.

Always use the supplied original signal cable in its ordered length. The cable lengths and cable extension (splitter) boxes are available to install the converter at a maximum cable distance of 30 meters of the sensor rails.

3.16.1 Pipe mounting

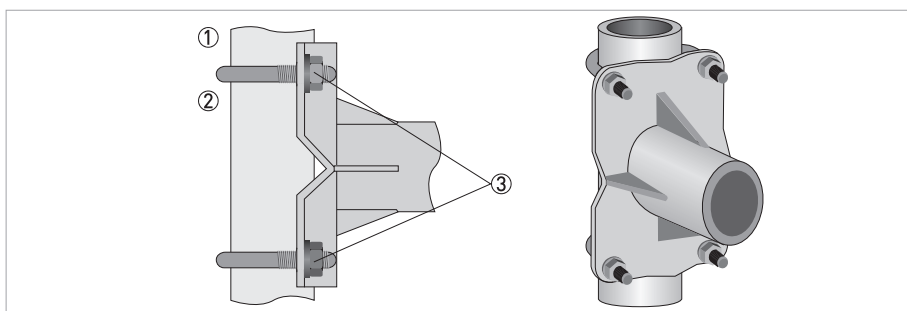

Figure 3-13: Pipe mounting of the field housing

- ① Fix the signal converter to the pipe.
- ② Fasten the signal converter using standard U-bolts and washers.
- ③ Tighten the nuts.

3.16.2 Wall mounting

Mounting the remote version (F) on the wall

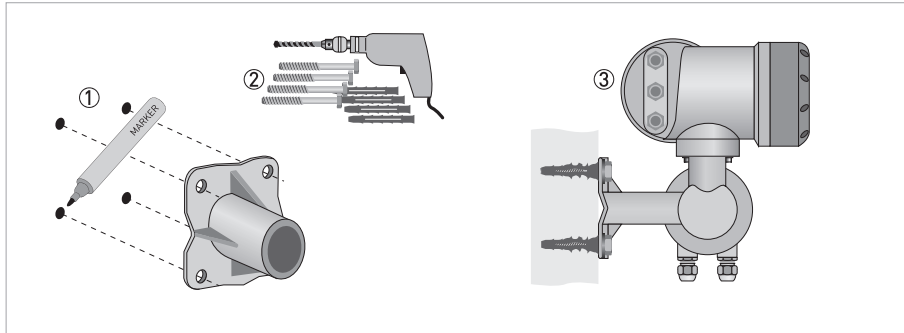

Figure 3-14: Wall mounting of the field housing

- ① Prepare the holes with the aid of the mounting plate. further information refer to *Mounting plate of field housing* on page 28.
- ② Use the mounting material and tools in compliance with the applicable occupational health and safety directives.
- ③ Fasten the housing securely to the wall.
- ④ Screw the signal converter to the mounting plate with the nuts and washers.

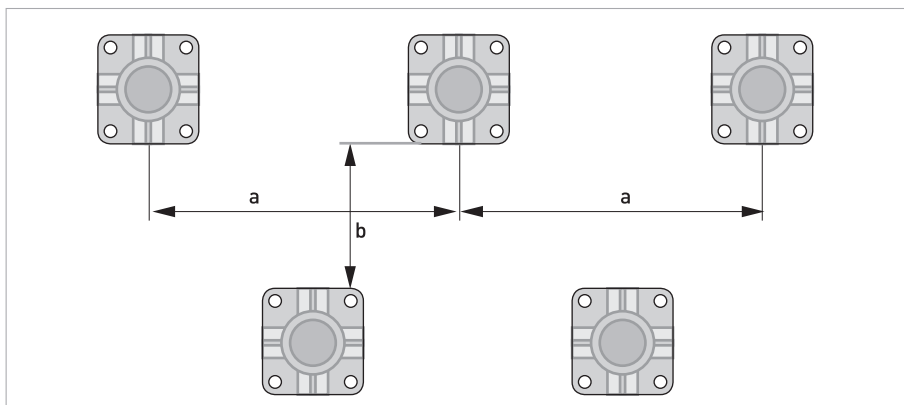

Figure 3-15: Mounting multiple devices next to each other

$a \geq 600 \text{ mm} / 23.6''$
 $b \geq 250 \text{ mm} / 9.8''$

Mounting the wall version (W)

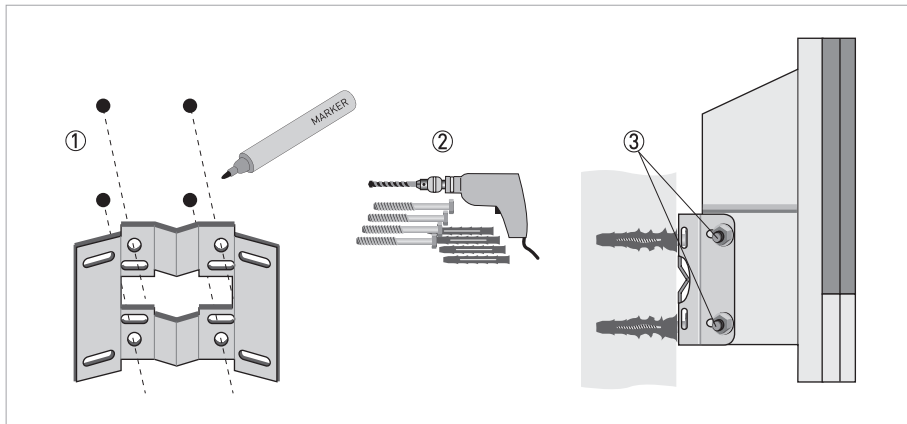

Figure 3-16: Wall mounting of the wall-mounted housing

- ① Prepare the holes with the aid of the mounting plate. For further information refer to *Mounting plate of wall-mounted housing* on page 28.
- ② Fasten the mounting plate securely to the wall.
- ③ Screw the signal converter to the mounting plate with the nuts and washers.

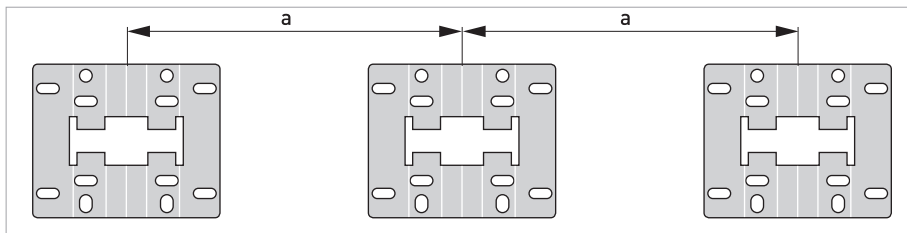

Figure 3-17: Mounting multiple devices next to each other
 $a \geq 240 \text{ mm} / 9.4''$

3.16.3 Turning the display of the field housing version

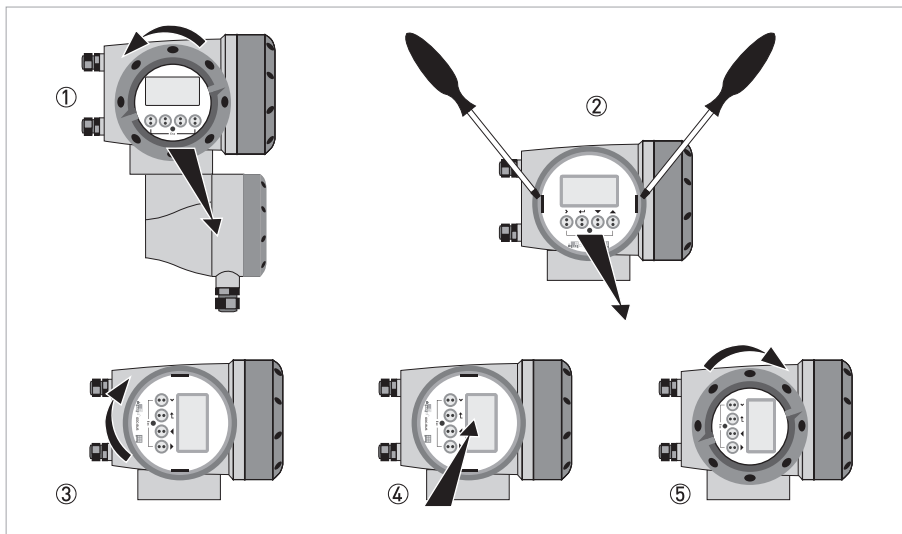

Figure 3-18: Turning the display of the field housing version

The display of the field housing version can be turned in 90° increments

- ① Unscrew the cover from the display and operation control unit.
- ② Using a suitable tool, pull out the two metal puller devices to the left and right of the display.
- ③ Pull out the display between the two metal puller devices and rotate it to the required position.
- ④ Slide the display and then the metal puller devices back into the housing.
- ⑤ Re-fit the cover and tighten it by hand.

The ribbon cable of the display must not be folded or twisted repeatedly.

Each time a housing cover is opened, the thread should be cleaned and greased. Use only resin-free and acid-free grease.

Ensure that the housing gasket is properly fitted, clean and undamaged.

4.1 Safety instructions

*All work on the electrical connections may only be carried out with the power disconnected.
Take note of the voltage data on the nameplate!*

Observe the national regulations for electrical installations!

For devices used in hazardous areas, additional safety notes apply; please refer to the Ex documentation.

*Observe without fail the local occupational health and safety regulations.
Any work done on the electrical components of the measuring device may only be carried out by properly trained specialists.*

*Look at the device nameplate to ensure that the device is delivered according to your order.
Check for the correct supply voltage printed on the nameplate.*

4.2 Laying electrical cables correctly

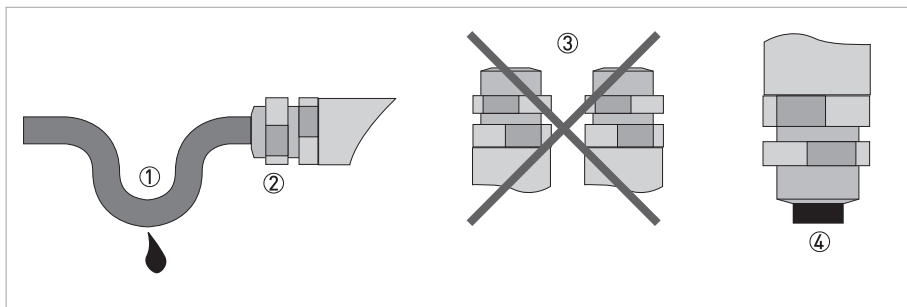

Figure 4-1: Protect housing from dust and water

- ① Lay the cable in a loop just before the housing.
- ② Tighten the screw connection of the cable entry securely.
- ③ Never mount the housing with the cable entries facing upwards.
- ④ Seal cable entries that are not needed with a plug.

4.3 Electrical connections signal converter

The connection of the flow sensor(s) to the signal converter depends on the version of the signal converter ordered.

Field version

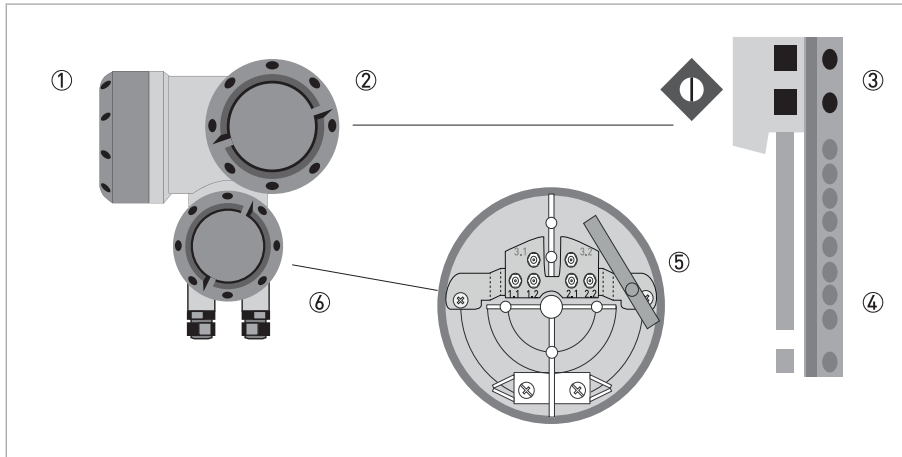

Figure 4-2: Construction of field version

- ① Cover, electronics compartment
- ② Cover, terminal compartment for power supply and inputs/outputs
- ③ Connectors for power
- ④ Connectors for inputs/outputs
- ⑤ Connectors for sensor cable
- ⑥ Cover, sensor terminal compartment

Wall version

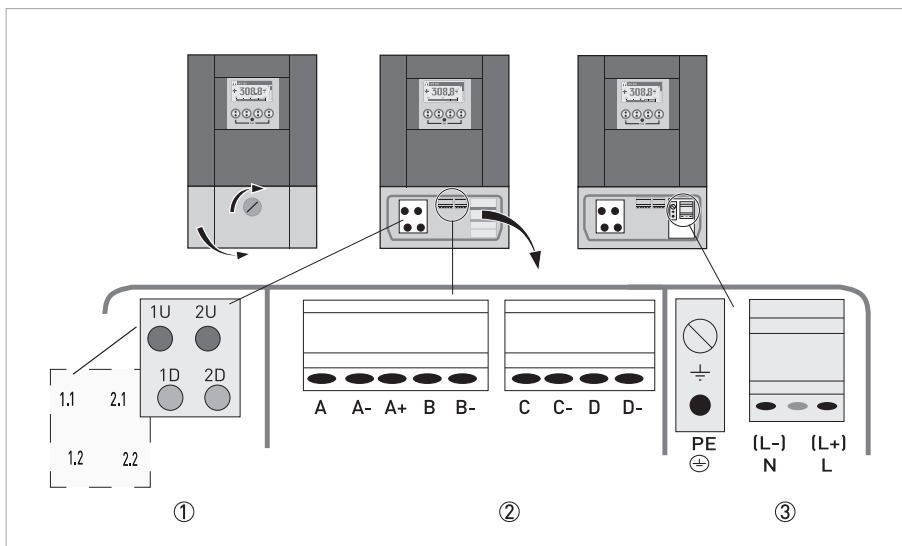

Figure 4-3: Construction of wall version

- ① Signal cable for sensors
- ② Communication I/O
- ③ Power supply: 24 VAC/DC or 100...230 VAC

This is a Class A product. In a domestic environment this product may cause radio interference in which case the user may be required to take adequate measures.

4.4 Power supply

If this device is intended for permanent connection to the mains, it is required (for example for service) to mount an external switch or circuit breaker near the device for disconnection from the mains. It shall be easily reachable by the operator and marked as the disconnecting device for this equipment.

The switch or circuit breaker and wiring has to be suitable for the application and shall also be in accordance with the local (safety) requirements of the (building) installation (e.g. IEC 60947-1 / -3).

For devices used in hazardous areas, additional safety notes apply; please refer to the Ex documentation.

The power terminals in the terminal compartments are equipped with additional hinged lids to prevent accidental contact.

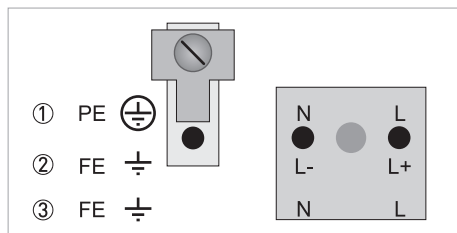

Figure 4-4: Power supply connection

- ① 100...230 VAC (-15% / +10%), 22 VA
- ② 24 VDC (-55% / +30%), 12 W
- ③ 24 VAC/DC (AC: -15% / +10%; DC: -25% / +30%), 22 VA or 12 W

The device must be grounded in accordance with regulations in order to protect personnel against electric shocks.

100...230 VAC (tolerance range: -15% / +10%)

- Note the power supply voltage and frequency (50...60 Hz) on the nameplate.
- The protective ground terminal **PE** of the power supply must be connected to the separate U-clamp terminal in the terminal compartment of the signal converter.

240 VAC+5% is included in the tolerance range.

24 VDC (tolerance range: -55% / +30%)

24 VAC/DC (tolerance ranges: AC: -15% / +10%; DC: -25% / +30%)

- Note the data on the nameplate!
- For measurement process reasons, a functional ground **FE** must be connected to the separate U-clamp terminal in the terminal compartment of the signal converter.
- When connecting to functional extra-low voltages, provide a facility for protective separation (PELV) (acc. to VDE 0100 / VDE 0106 and/or IEC 60364 / IEC 61140 or relevant national regulations).

For 24 VDC, 12 VDC-10% is included in the tolerance range.

4.4.1 Signal converter power supply connections

Field version

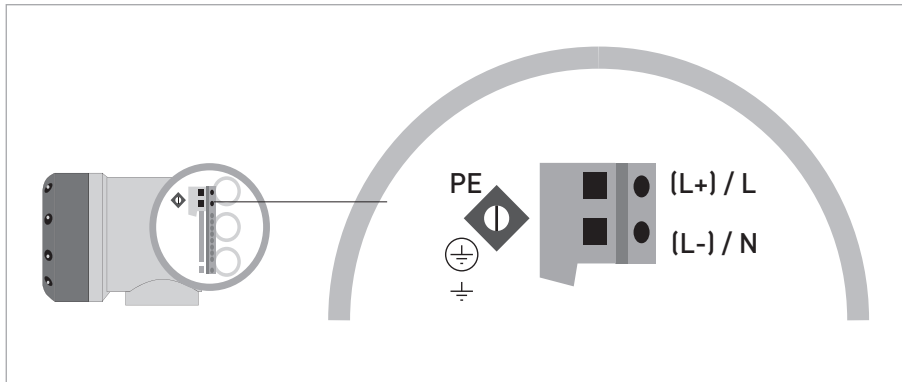

Figure 4-5: Signal converter field version, power supply connections

Wall version

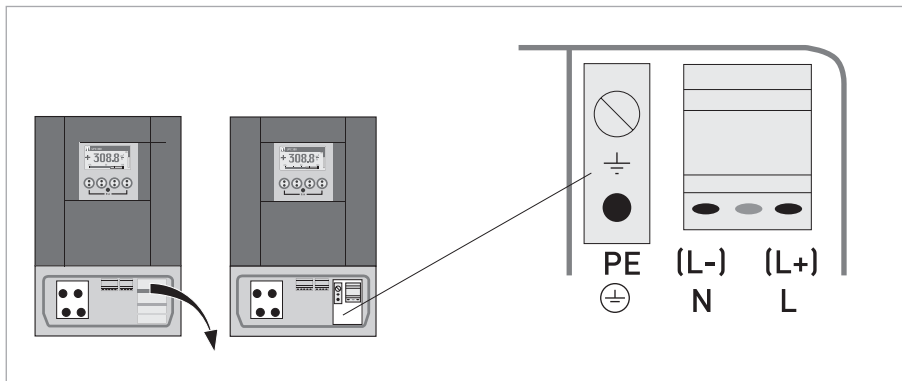

Figure 4-6: Signal converter wall version, power supply

4.4.2 Signal cable to converter

Each sensor rail has a signal cable which has to be connected, optional via a cable extension (splitter) box, to the signal converter. The inner cables are colour-coded and labelled to apply a correct connection of the acoustic paths.

Connect the cable to the connector with similar numeral marking.

Field version

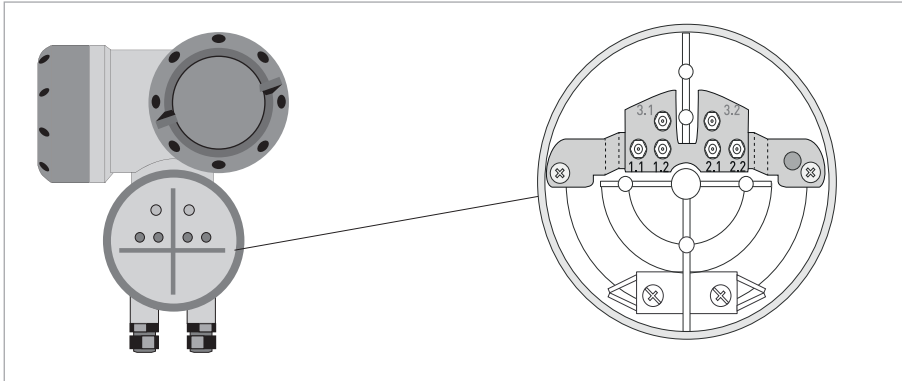

Figure 4-7: Connect signal cable

Construction of console (F-version)

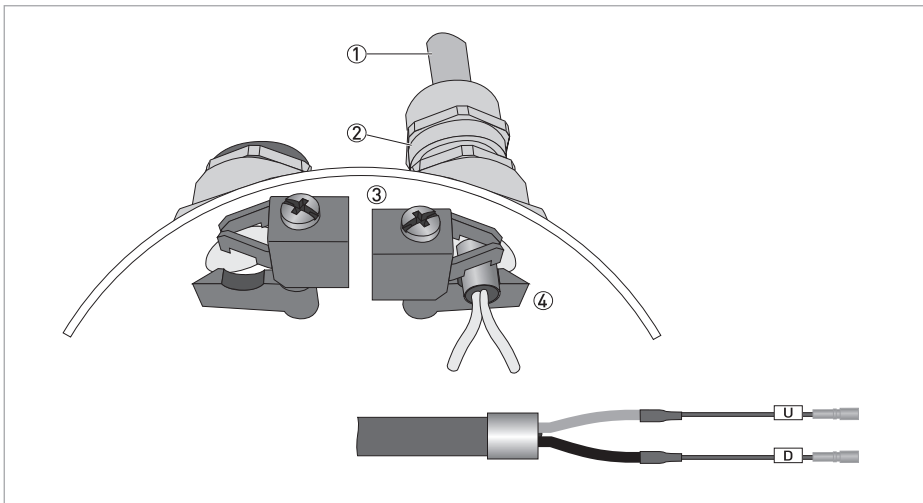

Figure 4-8: Inserting cable and secure with clamp on shielding bush

- ① Signal cable (blue or black)
- ② Cable glands
- ③ Grounding clamps
- ④ Signal cable with metal shielding bush and wire marking

Re-connecting of the coax connectors is limited. Make sure that the male connector on the coax cable, is always put straight on the female connector in the connection terminal of the unit. Excessive dis- / re-connection and/or positioning the connectors skewed to each other will damage the inside clips of the connectors. This results in an improper contact and measurement errors.

Cable insert and usage connector tool

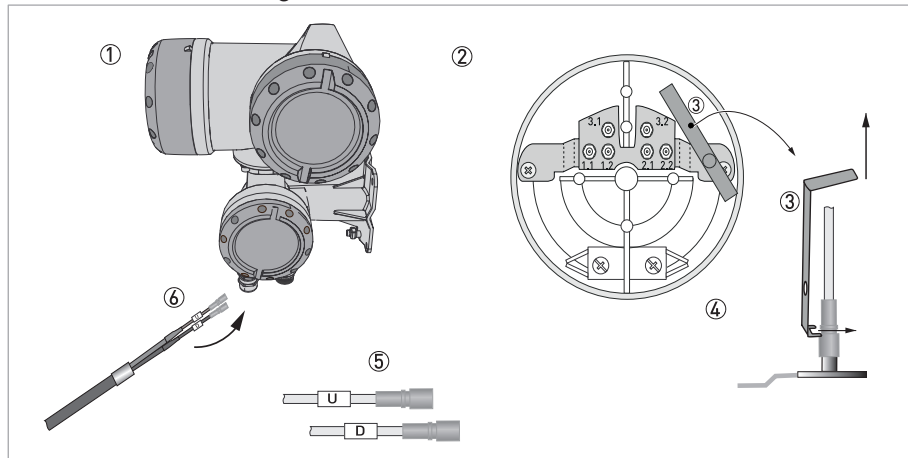

Figure 4-9: Construction of field version

- ① Signal converter
- ② Open connection terminal
- ③ Tool for releasing connectors
- ④ How to use the release tool
- ⑤ Marking on the cables
- ⑥ Insert cable(s) into connection terminal

Corresponding cable connections

Connections converter	Marking / color cable	Configuration	Transducer
1.1	U or 1.1 / Blue	1 path / 1 pipe	Upstream
1.2	D or 1.2 / Green	1 path / 1 pipe	Downstream
2.1	U or 2.1 / Blue	2 path / 2 pipes	Upstream
2.2	D or 2.2 / Green	2 path / 2 pipes	Downstream
3.1	not connected	-	-
3.2	not connected	-	-

Construction of console (W-version)

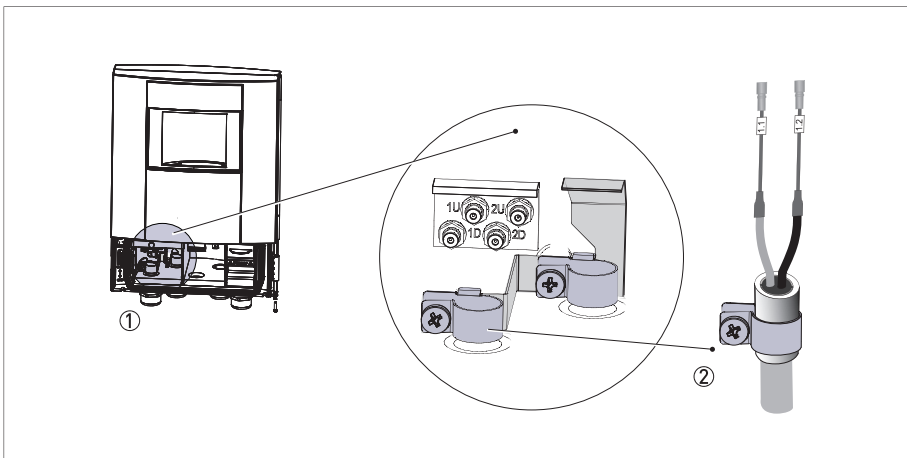

Figure 4-10: Inserting cable and secure with clamp on shielding bush

- ① Connection compartment sensor cable(s)
- ② Grounding clamp with metal shielding bush of sensor cable

Wall version

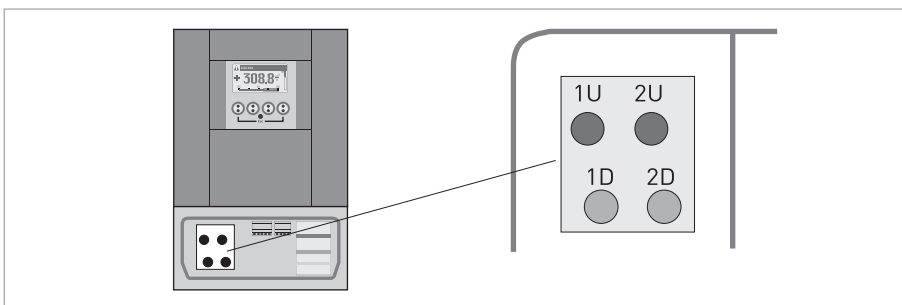

Figure 4-11: Connect signal cable

Corresponding cable connections

		Configuration	Transducer
U1	U or 1.1 / Blue	1 path / 1 pipe	Upstream
U2	U or 1.2 / Blue	2 path / 2 pipes	Upstream
D1	D or 2.1 / Green	1 path / 1 pipe	Downstream
D2	D or 2.2 / Green	2 path / 2 pipes	Downstream

4.4.3 Example of connecting the cable extension (splitter) box

The signal cable for the small and medium rails can be extended by using the cable (splitter) box with a single signal cable extension. The version for the large sensors in dual-path configuration has two signal cables from the up and down rail which are combined to a two-wire signal cable since the ultrasonic flow converter has two signal cable entries.

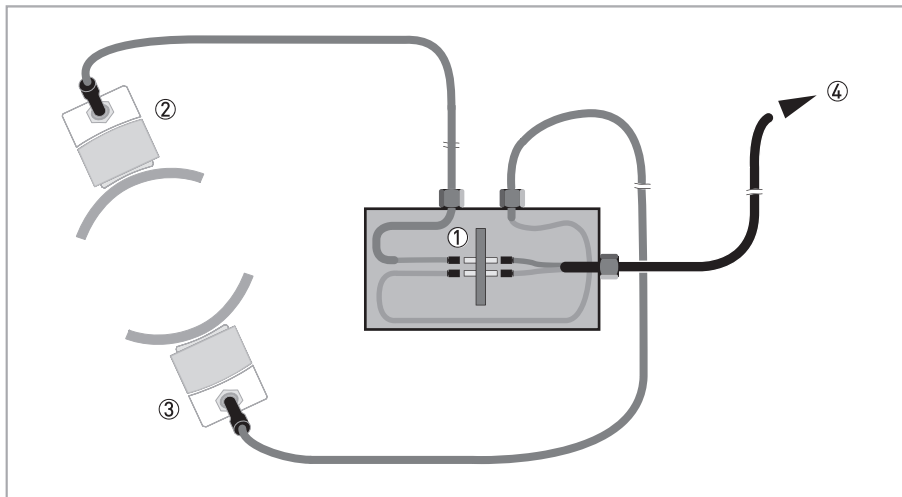

Figure 4-12: Example of large sensor rail connections with cable (splitter) box

- ① Cable (splitter) box connections
- ② Installed UP rail
- ③ Installed DOWN rail
- ④ Extension cable to UFC 300 signal converter

4.5 Modular inputs/outputs connections

All work on the electrical connections may only be carried out with the power disconnected.
Take note of the voltage data on the nameplate!

Observe connection polarity.

For frequencies above 100 Hz, shielded cables are to be used in order to reduce effects from electrical interferences (EMC).

Each time a housing cover is opened, the thread should be cleaned and greased. Use only resin-free and acid-free grease. Ensure that the housing gasket is properly fitted, clean and undamaged.

Field version

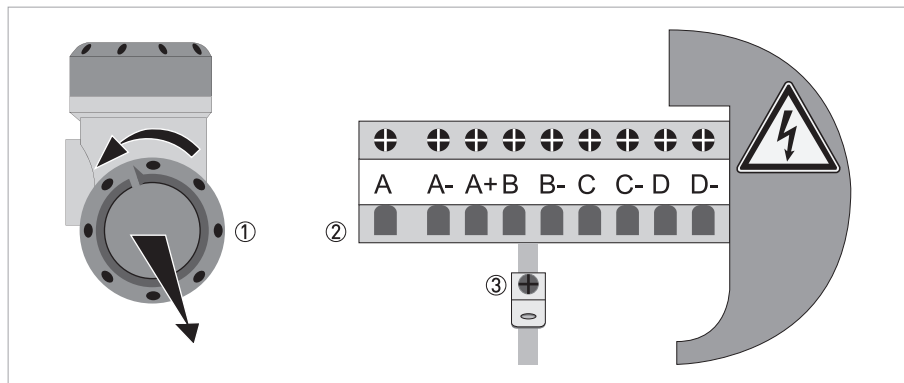

Figure 4-13: Terminal compartment for inputs and outputs of the field housing

- Open the housing cover ① and remove.
- Push the prepared cable through the cable entry and connect the necessary conductors ②.
- Connect the shield if necessary ③.

Wall version

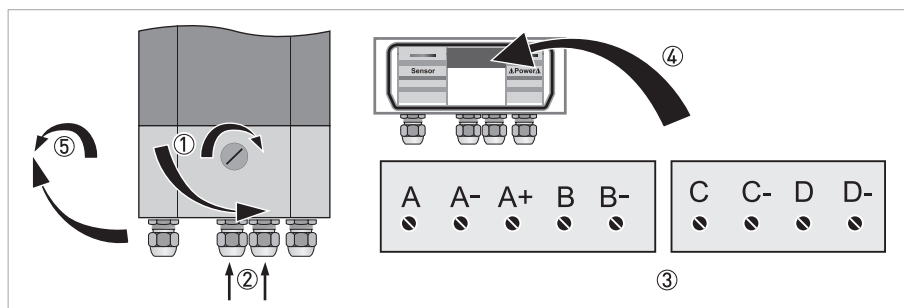

Figure 4-14: Terminal compartment for inputs and outputs of the wall-mounted housing

- Open the lock of the housing cover ① with screw driver (clockwise).
- Open bottom cover (terminal compartment).
- Push the prepared cable through the cable entry ② and connect the necessary conductors ③.
- Connect the shield if necessary ④.
- Close the cover of the terminal compartment.
- Lock ⑤ the housing cover with screw driver (counter clockwise).

4.5.1 Combinations of the inputs/outputs (I/Os)

This signal converter is available in Basic version with fixed outputs or as a Modular I/O with a flexible I/O configuration and communication within the available options.

Basic version

- Has 1 current output with HART 7, 1 pulse output and 2 status outputs / limit switches.
- The pulse output can be set as status output/limit switch and one of the status outputs as a control input.

Ex i version

- Depending on the task, the device can be configured with various output modules.
- Current outputs can be active or passive.
- Optionally available also with Foundation Fieldbus and Profibus PA

Modular version

- Depending on the task, the device can be configured with various output modules and up to 2 temperature inputs and/or communication protocols.

Bus systems

- The device allows intrinsically safe and non intrinsically safe bus interfaces in combination with additional modules.
- For connection and operation of bus systems, please note the supplementary manuals for the bus system.

Ex option

- For hazardous areas, all of the input/output variants with terminal compartment in the Ex d (pressure-resistant casing) or Ex e (increased safety) versions can be delivered.
- Please refer to the separate instructions for connection and operation of the Ex-devices.

4.5.2 Description of the CG-number



Figure 4-15: Marking (CG number) of the electronics module and input/output variants

- ① ID number:7
- ② ID number: 0 = standard
- ③ Power supply option
- ④ Display (language versions)
- ⑤ Input/output version (I/O)
- ⑥ 1st optional module for connection terminal A
- ⑦ 2nd optional module for connection terminal B

The last 3 digits of the CG number (⑤, ⑥ and ⑦) indicate the assignment of the terminal connections. Please refer to the following examples.

Examples for CG number

CG 370 x1 100	100...230 VAC & standard display; basic I/O: I_a or I_p & S_p/C_p & S_p & P_p/S_p
CG 370 x1 7FK	100...230 VAC & standard display; modular I/O: I_a & P_N/S_N and optional module P_N/S_N & C_N
CG 370 x1 4EB	24 VDC & standard display; modular I/O: I_a & P_a/S_a and optional module P_p/S_p & I_p

Description of abbreviations and CG identifier for possible optional modules on terminals A and B

Abbreviation	Identifier for CG No.	Description
I_a	A	Active current output
I_p	B	Passive current output
P_a / S_a	C	Active pulse output, frequency output, status output or limit switch (changeable)
P_p / S_p	E	Passive pulse output, frequency output, status output or limit switch (changeable)
P_N / S_N	F	Passive pulse output, frequency output, status output or limit switch acc. to NAMUR (changeable)
C_a	G	Active control input
C_p	K	Passive control input
C_N	H	Active control input to NAMUR Signal converter monitors cable breaks and short circuits acc. to NAMUR EN 60947-5-6. Errors indicated on LC display. Error messages possible via status output.
II_n_a	P	Active current input
II_n_p	R	Passive current input
2 x II_n_a	5	Two active current inputs (for Ex i I/O)
-	8	No additional module installed
-	0	No further module possible

4.5.3 Fixed, non-alterable input/output versions

This signal converter is available with various input/output combinations.

- The grey boxes in the tables denote unassigned or unused connection terminals.
- In the table, only the final digits of the CG no. are depicted.
- Connection terminal A+ is only operable in the basic input/output version.

CG no.	Connection terminals								
	A+	A	A-	B	B-	C	C-	D	D-

Basic I/Os (standard)

1 0 0		I _p + HART [®] passive ①	S _p / C _p passive ②	S _p passive	P _N / S _p passive ②
	I _a + HART [®] active ①				

Ex i I/Os (option)

2 0 0				I _a + HART [®] active	P _N / S _N NAMUR ②
3 0 0				I _p + HART [®] passive	P _N / S _N NAMUR ②
2 1 0		I _a active	P _N / S _N NAMUR C _p passive ②	I _a + HART [®] active	P _N / S _N NAMUR ②
3 1 0		I _a active	P _N / S _N NAMUR C _p passive ②	I _p + HART [®] passive	P _N / S _N NAMUR ②
2 2 0		I _p passive	P _N / S _N NAMUR C _p passive ②	I _a + HART [®] active	P _N / S _N NAMUR ②
3 2 0		I _p passive	P _N / S _N NAMUR C _p passive ②	I _p + HART [®] passive	P _N / S _N NAMUR ②
2 3 0		IIn _a active	P _N / S _N NAMUR C _p passive ②	I _a + HART [®] active	P _N / S _N NAMUR ②
3 3 0		IIn _a active	P _N / S _N NAMUR C _p passive ②	I _p + HART [®] passive	P _N / S _N NAMUR ②
2 4 0		IIn _p passive	P _N / S _N NAMUR C _p passive ②	I _a + HART [®] active	P _N / S _N NAMUR ②
3 4 0		IIn _p passive	P _N / S _N NAMUR C _p passive ②	I _p + HART [®] passive	P _N / S _N NAMUR ②
2 5 0		IIn _a active	IIn _a active		

① Function changed by reconnecting

② Changeable

- The grey boxes in the tables denote unassigned or unused connection terminals.
- Connection terminal A+ is only operable in the basic input/output version.

4.5.4 Alterable input/output versions

This signal converter is available with various input/output combinations.

- The grey boxes in the tables denote unassigned or unused connection terminals.
- In the table, only the final digits of the CG no. are depicted.
- Term. = (connection) terminal

CG no.	Connection terminals								
	A+	A	A-	B	B-	C	C-	D	D-

Modular IOs (option)

4 __		max. 2 optional modules for term. A + B	I _a + HART [®] active	P _a / S _a active ①
8 __		max. 2 optional modules for term. A + B	I _p + HART [®] passive	P _a / S _a active ①
6 __		max. 2 optional modules for term. A + B	I _a + HART [®] active	P _p / S _p passive ①
B __		max. 2 optional modules for term. A + B	I _p + HART [®] passive	P _p / S _p passive ①
7 __		max. 2 optional modules for term. A + B	I _a + HART [®] active	P _N / S _N NAMUR ①
C __		max. 2 optional modules for term. A + B	I _p + HART [®] passive	P _N / S _N NAMUR ①

PROFIBUS PA/DP

D __		max. 2 optional modules for term. A + B	PA+ (2)	PA- (2)	PA+ (1)	PA- (1)
F __		max. 2 optional modules for term. A + B	PA+ (2)	PA- (2)	PA+ (1)	PA- (1)

FOUNDATION Fieldbus (option)

E __		max. 2 optional modules for term. A + B	V/D+ (2)	V/D- (2)	V/D+ (1)	V/D- (1)
------	--	---	----------	----------	----------	----------

Modbus (option)

G __ ②		max. 2 optional modules for term. A + B		Common	Sign. B (D1)	Sign. A (D0)
--------	--	---	--	--------	--------------	--------------

① Changeable

② Not activated bus terminator

Please fill in this form and fax or email it to your local representative. Please include a sketch of the pipe layout as well, including the X, Y, Z dimensions.

Customer information

Date:	
Submitted by:	
Company:	
Address:	
Telephone:	
Fax:	
E-mail:	

Flow application data

Reference information (name, tag etc)	
New application Existing application, currently using:	
Measurement objective:	
Fluid:	
Flowrate	
Normal:	
Minimum:	
Maximum:	
Temperature	
Normal:	
Minimum:	
Maximum:	
Viscosity	
Normal:	
Maximum:	
Continuous / pulsating flow. Description:	
Entrained air percentage (volume):	
Entrained solids percentage (volume):	
Emulsion present (e.g. oil / water):	
Emulsion percentage product A:	
Emulsion percentage product B:	

Piping details

Nominal pipe size:	
Outer diameter:	
Wall thickness / schedule:	
Pipe material:	
Pipe condition (old / new / painted / internal scaling / exterior rust):	
Liner material:	
Liner thickness:	
Straight inlet / outlet section (DN):	
Upstream situation (elbows, valves, pumps):	
Flow orientation (vertical up / horizontal / vertical down / other):	

Environment details

Corrosive atmosphere:	
Sea water:	
High humidity (% R.H.):	
Nuclear (radiation):	
Hazardous area:	
Additional details:	

Hardware requirements:

Accuracy requested (percentage of rate):	
Power supply (voltage, AC / DC):	
Analog output (4-20 mA):	
Pulse (specify minimum pulse width, pulse value):	
Digital protocol:	
Options:	
Remote mounted signal converter: specify cable length:	
Accessories:	







KROHNE – Products, Solutions and Services

- Process instrumentation for flow, level, temperature, pressure measurement and process analytics
- Flow metering, monitoring, wireless and remote metering solutions
- Engineering, commissioning, calibration, maintenance and training services

Head Office KROHNE Messtechnik GmbH
Ludwig-Krohne-Str. 5
47058 Duisburg (Germany)
Tel.: +49 203 301 0
Fax: +49 203 301 10389
info@krohne.com

The current list of all KROHNE contacts and addresses can be found at:
www.krohne.com

